

# ***SYLVANIA***

# **SERVICE MANUAL**

**27" ANALOG/DIGITAL  
COLOR TELEVISION**

**6427GG**

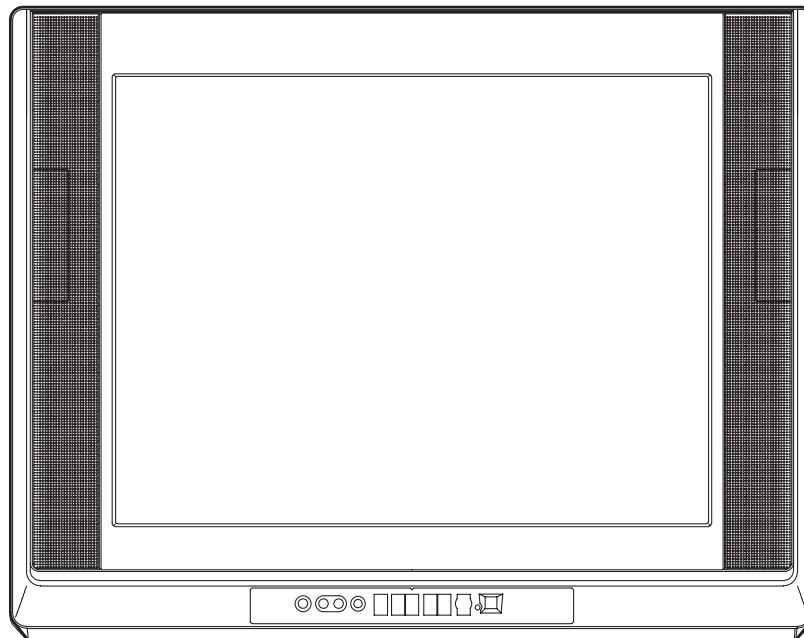

# IMPORTANT SAFETY NOTICE

Proper service and repair is important to the safe, reliable operation of all Funai Equipment. The service procedures recommended by Funai and described in this service manual are effective methods of performing service operations. Some of these service special tools should be used when and as recommended.

It is important to note that this service manual contains various CAUTIONS and NOTICES which should be carefully read in order to minimize the risk of personal injury to service personnel. The possibility exists that improper service methods may damage the equipment. It also is important to understand that these CAUTIONS and NOTICES ARE NOT EXHAUSTIVE. Funai could not possibly know, evaluate and advice the service trade of all conceivable ways in which service might be done or of the possible hazardous consequences of each way. Consequently, Funai has not undertaken any such broad evaluation. Accordingly, a servicer who uses a service procedure or tool which is not recommended by Funai must first use all precautions thoroughly so that neither his safety nor the safe operation of the equipment will be jeopardized by the service method selected.

## TABLE OF CONTENTS

Specifications . . . . .	1-1
Important Safety Precautions . . . . .	2-1
Standard Notes for Servicing . . . . .	3-1
Cabinet Disassembly Instructions . . . . .	4-1
Electrical Adjustment Instructions . . . . .	5-1
How to initialize the Analog/Digital Color Television . . . . .	6-1
Block Diagrams . . . . .	7-1
Schematic Diagrams / CBA's and Test Points . . . . .	8-1
Waveforms . . . . .	9-1
Wiring Diagram . . . . .	10-1
IC Pin Function Descriptions . . . . .	11-1
Exploded Views . . . . .	12-1
Mechanical Parts List . . . . .	13-1
Electrical Parts List . . . . .	14-1

# SPECIFICATIONS

## Test input

Video input: 1V p-p

Audio input: 500mV rms

Tuner: Ant input (80dBuV) Video 87.5%

## < DEFLECTION >

Description	Condition	Unit	Limit
1. Over Scan	Horizontal Vertical	% %	90±5 90±5
2. Linearity	Horizontal Vertical	% %	±15 ±10
3. High Voltage	---	kV	25 to 33

## < VIDEO & CHROMA >

Description	Condition	Unit	Limit
1. Contrast control range	---	dB	>6
2. Brightness	APL 100%	ft-L	>20
3. Color Temperature	---	°K	9200

## < TUNER >

Description	Condition	Unit	Limit
1. Video S/N	---	dB	>43
2. Audio S/N (W/LPF)	---	dB	>45

## < ATSC >

Description	Condition	Unit	Limit
1. RECEIVED FREQ. RANGE (-28dBm)	+	kHz	>100
	-	kHz	>100
2. ATSC DYNAMIC RANGE (min./max.) VHF LOW BAND. CH.4 VHF HI BAND. CH.10 UHF BAND. CH.41	---	dBm	-76/0
		dBm	-76/0
		dBm	-74/4
3. ATSC SUSCEPTIBILITY TO RANDOM NOISE VHF LOW BAND. CH.4 VHF HI BAND. CH.10 UHF BAND. CH.41	---	dB	<26
		dB	<26
		dB	<26
4. NTSC CO-CHANNEL INTERFERENCE VHF LOW BAND. CH.4 VHF HI BAND. CH.10 UHF BAND. CH.41	---	dB	>-6
		dB	>-6
		dB	>-6

Description	Condition	Unit	Limit
5. MULTIPATH	A	dB	<6
	B	dB	<6
	C	dB	<6
	D	dB	<6
	E	dB	<6
	F	dB	<6
	FF	dB	<6
	G	dB	<6
6. Audio S/N (0dBfs)	L	dB	>50
	R	dB	>50
7. Audio DIST. (0dBfs)	L	%	<3
	R	%	<3

**Note:** Nominal specifications represent the design specifications. All units should be able to approximate these. Some will exceed and some may drop slightly below these specifications. Limit specifications represent the absolute worst condition that still might be considered acceptable. In no case should a unit fail to meet limit specifications.

# IMPORTANT SAFETY PRECAUTIONS

Prior to shipment from the factory, our products are strictly inspected for recognized product safety and electrical codes of the countries in which they are to be sold. However, in order to maintain such compliance, it is equally important to implement the following precautions when a set is being serviced.

## Safety Precautions for TV Circuit

1. **Before returning an instrument to the customer**, always make a safety check of the entire instrument, including, but not limited to, the following items:
  - a. Be sure that no built-in protective devices are defective and have been defeated during servicing. (1) Protective shields are provided on this chassis to protect both the technician and the customer. Correctly replace all missing protective shields, including any removed for servicing convenience. (2) When reinstalling the chassis and/or other assembly in the cabinet, be sure to put back in place all protective devices, including but not limited to, nonmetallic control knobs, insulating fishpapers, adjustment and compartment covers/shields, and isolation resistor/capacitor networks. **Do not operate this instrument or permit it to be operated without all protective devices correctly installed and functioning. Servicers who defeat safety features or fail to perform safety checks may be liable for any resulting damage.**
  - b. Be sure that there are no cabinet openings through which an adult or child might be able to insert their fingers and contact a hazardous voltage. Such openings include, but are not limited to, (1) spacing between the picture tube and the cabinet mask, (2) excessively wide cabinet ventilation slots, and (3) an improperly fitted and/or incorrectly secured cabinet back cover.
  - c. **Antenna Cold Check** - With the instrument AC plug removed from any AC source, connect an electrical jumper across the two AC plug prongs. Place the instrument AC switch in the on position. Connect one lead of an ohmmeter to the AC plug prongs tied together and touch the other ohmmeter lead in turn to each tuner antenna input exposed terminal screw and, if applicable, to the coaxial connector. If the measured resistance is less than 1.0 megohm or greater than 5.2 megohm, an abnormality exists that must be corrected before the instrument is returned to the customer. Repeat this test with the instrument AC switch in the off position.
  - d. **Leakage Current Hot Check** - With the instrument completely reassembled, plug the

AC line cord directly into a 120 V AC outlet. (Do not use an isolation transformer during this test.) Use a leakage current tester or a metering system that complies with American National Standards Institute (ANSI) C101.1 Leakage Current for Appliances and Underwriters Laboratories (UL) 1410, (50.7). With the instrument AC switch first in the on position and then in the off position, measure from a known earth ground (metal water pipe, conduit, etc.) to all exposed metal parts of the instrument (antennas, handle brackets, metal cabinet, screw heads, metallic overlays, control shafts, etc.), especially any exposed metal parts that offer an electrical return path to the chassis. Any current measured must not exceed 0.5 milli-ampere. Reverse the instrument power cord plug in the outlet and repeat the test.

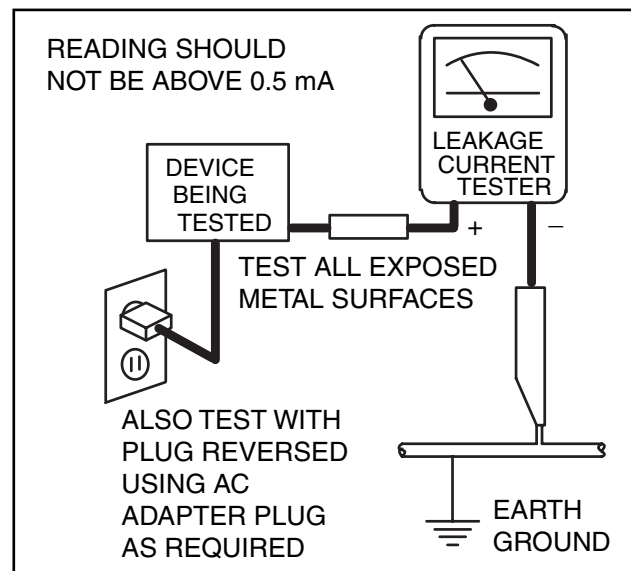

**ANY MEASUREMENTS NOT WITHIN THE LIMITS SPECIFIED HEREIN INDICATE A POTENTIAL SHOCK HAZARD THAT MUST BE ELIMINATED BEFORE RETURNING THE INSTRUMENT TO THE CUSTOMER OR BEFORE CONNECTING THE ANTENNA OR ACCESSORIES.**

- e. **X-Radiation and High Voltage Limits** - Because the picture tube is the primary potential source of X-radiation in solid-state TV receivers, it is specially constructed to prohibit X-radiation emissions. For continued X-radiation protection, the replacement picture tube must be the same type as the original.

Also, because the picture tube shields and mounting hardware perform an X-radiation protection function, they must be correctly in place. High voltage must be measured each time servicing is performed that involves B+, horizontal deflection or high voltage. Correct operation of the X-radiation protection circuits also must be reconfirmed each time they are serviced. (X-radiation protection circuits also may be called “horizontal disable” or “hold down.”) Read and apply the high voltage limits and, if the chassis is so equipped, the X-radiation protection circuit specifications given on instrument labels and in the Product Safety & X-Radiation Warning note on the service data chassis schematic. High voltage is maintained within specified limits by close tolerance safety-related components/adjustments in the high-voltage circuit. If high voltage exceeds specified limits, check each component specified on the chassis schematic and take corrective action.

2. Read and comply with all caution and safety-related notes on or inside the receiver cabinet, on the receiver chassis, or on the picture tube.
3. **Design Alteration Warning** - Do not alter or add to the mechanical or electrical design of this TV receiver. Design alterations and additions, including, but not limited to circuit modifications and the addition of items such as auxiliary audio and/or video output connections, might alter the safety characteristics of this receiver and create a hazard to the user. Any design alterations or additions will void the manufacturer's warranty and may make you, the servicer, responsible for personal injury or property damage resulting therefrom.
4. **Picture Tube Implosion Protection Warning** - The picture tube in this receiver employs integral implosion protection. For continued implosion protection, replace the picture tube only with one of the same type number. Do not remove, install, or otherwise handle the picture tube in any manner without first putting on shatterproof goggles equipped with side shields. People not so equipped must be kept safely away while picture tubes are handled. Keep the picture tube away from your body. Do not handle the picture tube by its neck. Some “in-line” picture tubes are equipped with a permanently attached deflection yoke; because of potential hazard, do not try to remove such “permanently attached” yokes from the picture tube.
5. **Hot Chassis Warning** -
  - a. Some TV receiver chassis are electrically connected directly to one conductor of the AC power cord and maybe safety-serviced without

an isolation transformer only if the AC power plug is inserted so that the chassis is connected to the ground side of the AC power source. To confirm that the AC power plug is inserted correctly, with an AC voltmeter, measure between the chassis and a known earth ground. If a voltage reading in excess of 1.0V is obtained, remove and reinsert the AC power plug in the opposite polarity and again measure the voltage potential between the chassis and a known earth ground.

- b. Some TV receiver chassis normally have 85V AC(RMS) between chassis and earth ground regardless of the AC plug polarity. This chassis can be safety-serviced only with an isolation transformer inserted in the power line between the receiver and the AC power source, for both personnel and test equipment protection.
  - c. Some TV receiver chassis have a secondary ground system in addition to the main chassis ground. This secondary ground system is not isolated from the AC power line. The two ground systems are electrically separated by insulation material that must not be defeated or altered.
6. Observe original lead dress. Take extra care to assure correct lead dress in the following areas: a. near sharp edges, b. near thermally hot parts-be sure that leads and components do not touch thermally hot parts, c. the AC supply, d. high voltage, and, e. antenna wiring. Always inspect in all areas for pinched, out of place, or frayed wiring. Check AC power cord for damage.
  7. Components, parts, and/or wiring that appear to have overheated or are otherwise damaged should be replaced with components, parts, or wiring that meet original specifications. Additionally, determine the cause of overheating and/or damage and, if necessary, take corrective action to remove any potential safety hazard.
  8. **Product Safety Notice** - Some electrical and mechanical parts have special safety-related characteristics which are often not evident from visual inspection, nor can the protection they give necessarily be obtained by replacing them with components rated for higher voltage, wattage, etc. Parts that have special safety characteristics are identified by a  on schematics and in parts lists. Use of a substitute replacement that does not have the same safety characteristics as the recommended replacement part might create shock, fire, and/or other hazards. The product's safety is under review continuously and new instructions are issued whenever appropriate. Prior to shipment from the factory, our products are strictly inspected to confirm they comply with the recognized product safety and electrical codes

of the countries in which they are to be sold. However, in order to maintain such compliance, it is equally important to implement the following precautions when a set is being serviced.

## Precautions during Servicing

- A.** Parts identified by the  symbol are critical for safety.  
Replace only with part number specified.
- B.** In addition to safety, other parts and assemblies are specified for conformance with regulations applying to spurious radiation. These must also be replaced only with specified replacements.  
Examples: RF converters, RF cables, noise blocking capacitors, and noise blocking filters, etc.
- C.** Use specified internal wiring. Note especially:
  - 1) Wires covered with PVC tubing
  - 2) Double insulated wires
  - 3) High voltage leads
- D.** Use specified insulating materials for hazardous live parts. Note especially:
  - 1) Insulation Tape
  - 2) PVC tubing
  - 3) Spacers
  - 4) Insulators for transistors.
- E.** When replacing AC primary side components (transformers, power cord, etc.), wrap ends of wires securely about the terminals before soldering.
- F.** Observe that the wires do not contact heat producing parts (heat sinks, oxide metal film resistors, fusible resistors, etc.)
- G.** Check that replaced wires do not contact sharp edged or pointed parts.
- H.** When a power cord has been replaced, check that 5~6 kg of force in any direction will not loosen it.
- I.** Also check areas surrounding repaired locations.
- J.** Use care that foreign objects (screws, solder droplets, etc.) do not remain inside the set.
- K.** Crimp type wire connector  
The power transformer uses crimp type connectors which connect the power cord and the primary side of the transformer. When replacing the transformer, follow these steps carefully and precisely to prevent shock hazards.  
Replacement procedure
  - 1) Remove the old connector by cutting the wires at a point close to the connector.  
Important: Do not re-use a connector (discard it).
  - 2) Strip about 15 mm of the insulation from the ends of the wires. If the wires are stranded, twist the strands to avoid frayed conductors.

- 3) Align the lengths of the wires to be connected. Insert the wires fully into the connector.
  - 4) Use the crimping tool to crimp the metal sleeve at the center position. Be sure to crimp fully to the complete closure of the tool.
- L.** When connecting or disconnecting the internal connectors, first, disconnect the AC plug from the AC supply outlet.

## Safety Check after Servicing

Examine the area surrounding the repaired location for damage or deterioration. Observe that screws, parts and wires have been returned to original positions. Afterwards, perform the following tests and confirm the specified values in order to verify compliance with safety standards.

### 1. Clearance Distance

When replacing primary circuit components, confirm specified clearance distance ( $d$ ) and ( $d'$ ) between soldered terminals, and between terminals and surrounding metallic parts. (See Fig. 1)

**Table 1: Ratings for selected area**

AC Line Voltage	Region	Clearance Distance ( $d$ ), ( $d'$ )
110 to 130 V	U.S.A. or Canada	$\geq 3.2$ mm (0.126 inches)

**Note:** This table is unofficial and for reference only. Be sure to confirm the precise values.

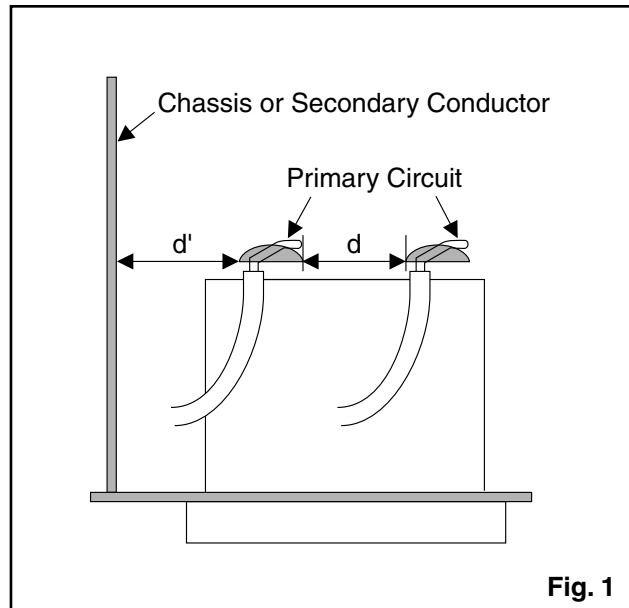

**Fig. 1**

### 2. Leakage Current Test

Confirm the specified (or lower) leakage current between B (earth ground, power cord plug prongs) and externally exposed accessible parts (RF terminals, antenna terminals, video and audio input and output terminals, microphone jacks, earphone jacks, etc.) is lower than or equal to the specified value in the table below.

#### Measuring Method: (Power ON)

Insert load Z between B (earth ground, power cord plug prongs) and exposed accessible parts. Use an AC voltmeter to measure across both terminals of load Z. See Fig. 2 and following table.

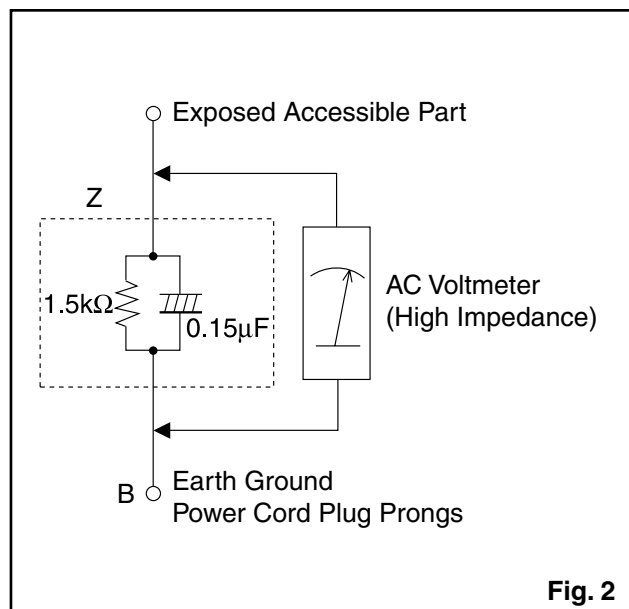

**Fig. 2**

**Table 2: Leakage current ratings for selected areas**

AC Line Voltage	Region	Load Z	Leakage Current ( $i$ )	Earth Ground (B) to:
110 to 130 V	U.S.A. or Canada	0.15 $\mu$ F CAP. & 1.5 k $\Omega$ RES. Connected in parallel	$i \leq 0.5$ mA rms	Exposed accessible parts

**Note:** This table is unofficial and for reference only. Be sure to confirm the precise values.



# STANDARD NOTES FOR SERVICING

## Circuit Board Indications

1. The output pin of the 3 pin Regulator ICs is indicated as shown.

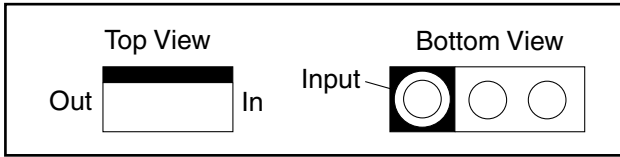

2. For other ICs, pin 1 and every fifth pin are indicated as shown.

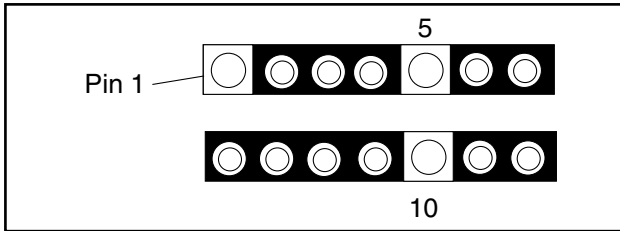

3. The 1st pin of every male connector is indicated as shown.

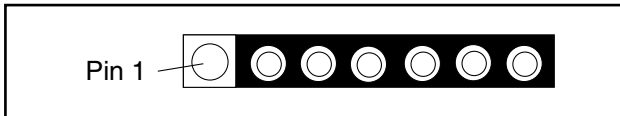

## Pb (Lead) Free Solder

**Pb free mark will be found on PCBs which use Pb free solder. (Refer to figure.) For PCBs with Pb free mark, be sure to use Pb free solder. For PCBs without Pb free mark, use standard solder.**

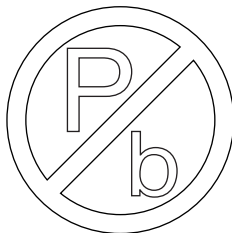

Pb free mark

## How to Remove / Install Flat Pack-IC

### 1. Removal

**With Hot-Air Flat Pack-IC Desoldering Machine:**

1. Prepare the hot-air flat pack-IC desoldering machine, then apply hot air to the Flat Pack-IC (about 5 to 6 seconds). (Fig. S-1-1)

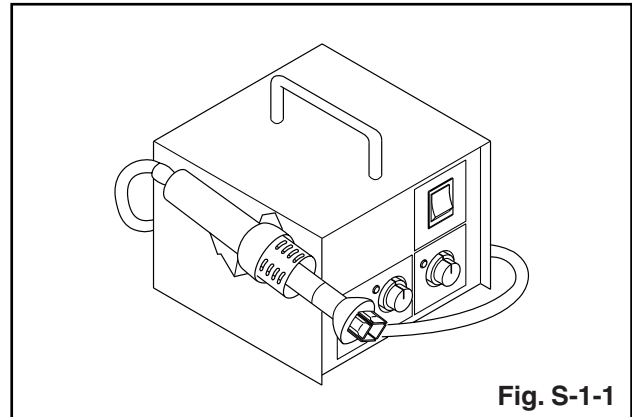

Fig. S-1-1

2. Remove the flat pack-IC with tweezers while applying the hot air.
3. Bottom of the flat pack-IC is fixed with glue to the CBA; when removing entire flat pack-IC, first apply soldering iron to center of the flat pack-IC and heat up. Then remove (glue will be melted). (Fig. S-1-6)
4. Release the flat pack-IC from the CBA using tweezers. (Fig. S-1-6)

### CAUTION:

1. The Flat Pack-IC shape may differ by models. Use an appropriate hot-air flat pack-IC desoldering machine, whose shape matches that of the Flat Pack-IC.
2. Do not supply hot air to the chip parts around the flat pack-IC for over 6 seconds because damage to the chip parts may occur. Put masking tape around the flat pack-IC to protect other parts from damage. (Fig. S-1-2)

3. The flat pack-IC on the CBA is affixed with glue, so be careful not to break or damage the foil of each pin or the solder lands under the IC when removing it.

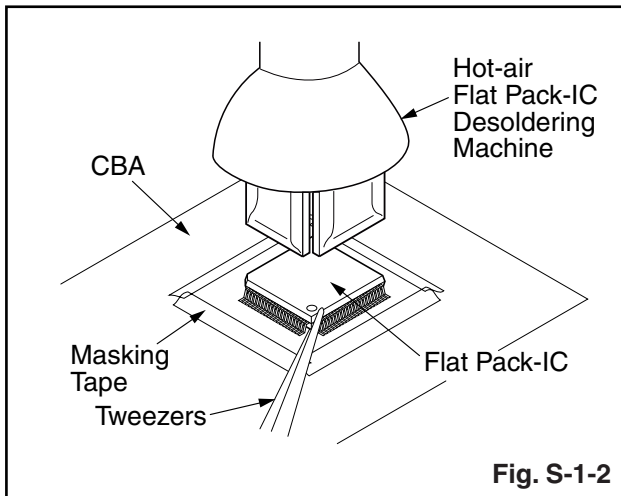

#### With Soldering Iron:

1. Using desoldering braid, remove the solder from all pins of the flat pack-IC. When you use solder flux which is applied to all pins of the flat pack-IC, you can remove it easily. (Fig. S-1-3)

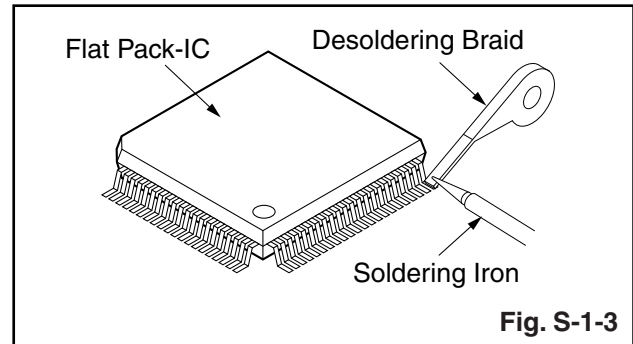

2. Lift each lead of the flat pack-IC upward one by one, using a sharp pin or wire to which solder will not adhere (iron wire). When heating the pins, use a fine tip soldering iron or a hot air desoldering machine. (Fig. S-1-4)

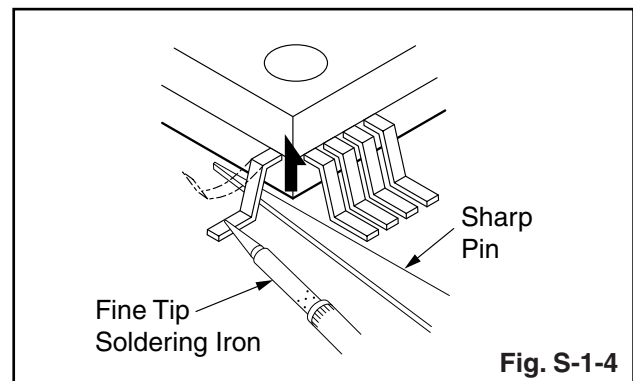

3. Bottom of the flat pack-IC is fixed with glue to the CBA; when removing entire flat pack-IC, first apply soldering iron to center of the flat pack-IC and heat up. Then remove (glue will be melted). (Fig. S-1-6)
4. Release the flat pack-IC from the CBA using tweezers. (Fig. S-1-6)

### With Iron Wire:

1. Using desoldering braid, remove the solder from all pins of the flat pack-IC. When you use solder flux which is applied to all pins of the flat pack-IC, you can remove it easily. (Fig. S-1-3)
2. Affix the wire to a workbench or solid mounting point, as shown in Fig. S-1-5.
3. While heating the pins using a fine tip soldering iron or hot air blower, pull up the wire as the solder melts so as to lift the IC leads from the CBA contact pads as shown in Fig. S-1-5.
4. Bottom of the flat pack-IC is fixed with glue to the CBA; when removing entire flat pack-IC, first apply soldering iron to center of the flat pack-IC and heat up. Then remove (glue will be melted). (Fig. S-1-6)
5. Release the flat pack-IC from the CBA using tweezers. (Fig. S-1-6)

**Note:** When using a soldering iron, care must be taken to ensure that the flat pack-IC is not being held by glue. When the flat pack-IC is removed from the CBA, handle it gently because it may be damaged if force is applied.

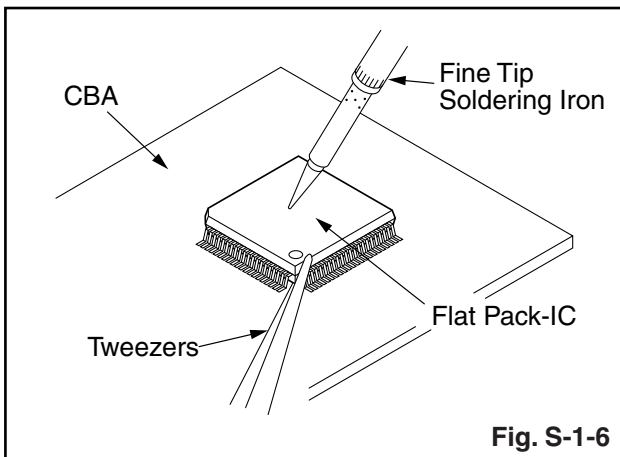
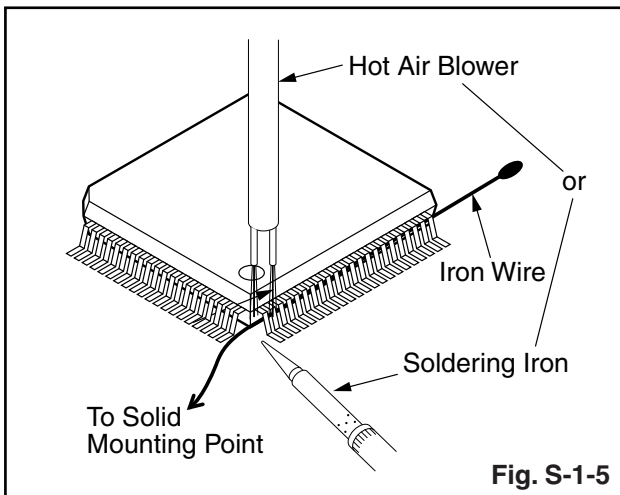

## 2. Installation

1. Using desoldering braid, remove the solder from the foil of each pin of the flat pack-IC on the CBA so you can install a replacement flat pack-IC more easily.
2. The "●" mark on the flat pack-IC indicates pin 1. (See Fig. S-1-7.) Be sure this mark matches the 1 on the PCB when positioning for installation. Then presolder the four corners of the flat pack-IC. (See Fig. S-1-8.)
3. Solder all pins of the flat pack-IC. Be sure that none of the pins have solder bridges.

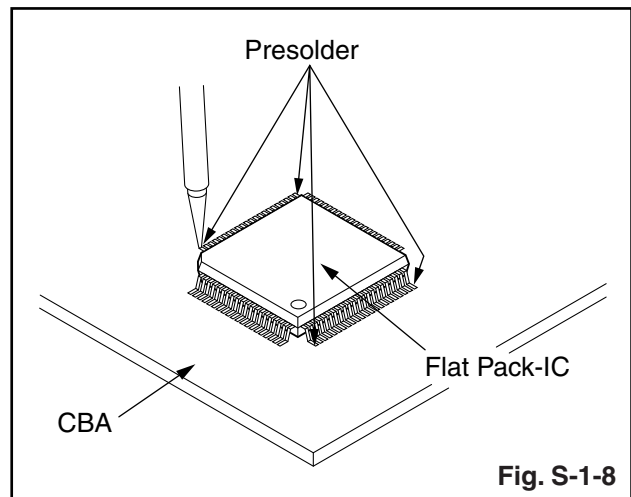
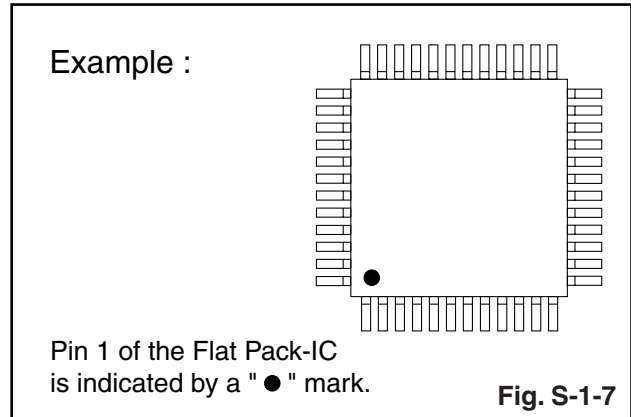

# Instructions for Handling Semi-conductors

Electrostatic breakdown of the semi-conductors may occur due to a potential difference caused by electrostatic charge during unpacking or repair work.

## 1. Ground for Human Body

Be sure to wear a grounding band (1 M $\Omega$ ) that is properly grounded to remove any static electricity that may be charged on the body.

## 2. Ground for Workbench

Be sure to place a conductive sheet or copper plate with proper grounding (1 M $\Omega$ ) on the workbench or other surface, where the semi-conductors are to be placed. Because the static electricity charge on clothing will not escape through the body grounding band, be careful to avoid contacting semi-conductors with your clothing.

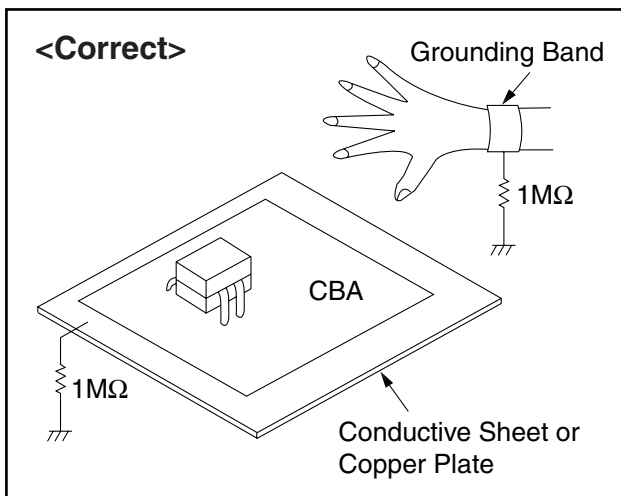
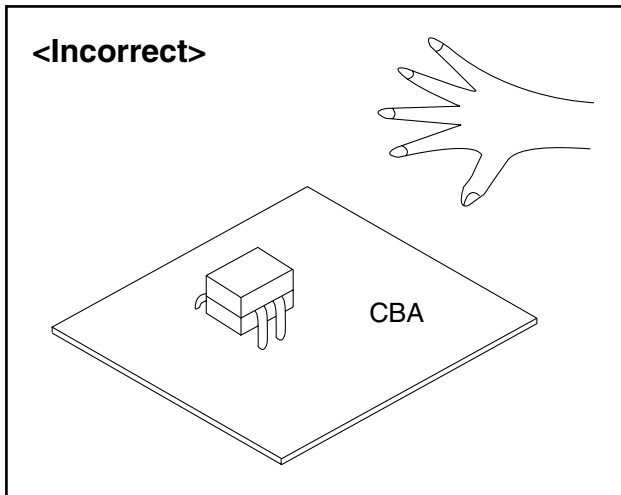

# CABINET DISASSEMBLY INSTRUCTIONS

## 1. Disassembly Flowchart

This flowchart indicates the disassembly steps for the cabinet parts, and the CBA in order to gain access to item(s) to be serviced. When reassembling, follow the steps in reverse order. Bend, route and dress the cables as they were.

### CAUTION!

When removing the CRT, be sure to discharge the Anode Lead of the CRT with the CRT Ground Wire before removing the Anode Cap.

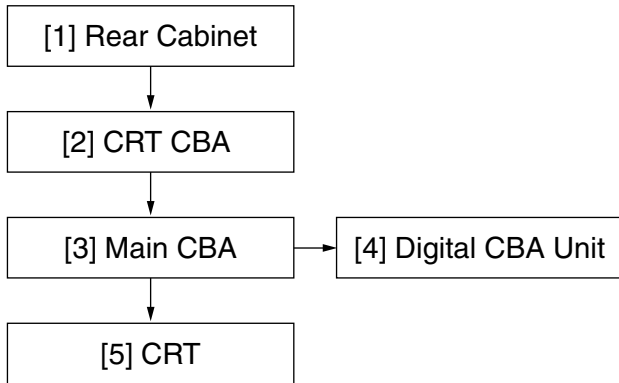

## 2. Disassembly Method

Step/ Loc. No.	Part	Removal		
		Fig. No.	Remove/*Unhook/ Unlock/Release/ Unplug/Unclamp/ Desolder	Note
[1]	Rear Cabinet	D1 D2	9(S-1), 4(S-2), (S-3)	1
[2]	CRT CBA	D4 D5	CN1501	2
[3]	Main CBA	D3 D4 D5	CN801, CN802, CN571, CN691, Anode Cap	3
[4]	Digital CBA Unit	D3 D5	CN901, CN902	4
[5]	CRT	D4	4(S-4)	5

↓                      ↓                      ↓                      ↓                      ↓  
 (1)                    (2)                    (3)                    (4)                    (5)

### Note:

- (1) Order of steps in procedure. When reassembling, follow the steps in reverse order. These numbers are also used as the Identification (location) No. of parts in figures.
- (2) Parts to be removed or installed.
- (3) Fig. No. showing procedure of part location
- (4) Identification of parts to be removed, unhooked, unlocked, released, unplugged, unclamped, or desoldered.  
 P = Spring, L = Locking Tab, S = Screw,  
 CN = Connector  
 \* = Unhook, Unlock, Release, Unplug, or Desolder  
 e.g. 2(S-2) = two Screws (S-2),  
       2(L-2) = two Locking Tabs (L-2)
- (5) Refer to the following "Reference Notes in the Table."

### Reference Notes in the Table

1. Removal of the Rear Cabinet: Remove screws 9(S-1), 4(S-2) and (S-3) then slide the Rear Cabinet backward.
2. Removal of the CRT CBA: Disconnect CN1501 then pull the CRT CBA backward.
3. Removal of the Main CBA:  
**CAUTION:** Discharge the Anode Lead of the CRT with the CRT Ground Wire before removing the Anode Cap.  
 Disconnect CN801, CN802, CN571 and CN691 on the Main CBA and remove Anode Cap. Then slide the Main CBA backward.
4. Removal of the Digital CBA Unit: Disconnect CN901 and CN902 on the Digital CBA Unit then remove the Digital CBA Unit.
5. Removal of the CRT: Remove screws 4(S-4). Then slide the CRT backward.

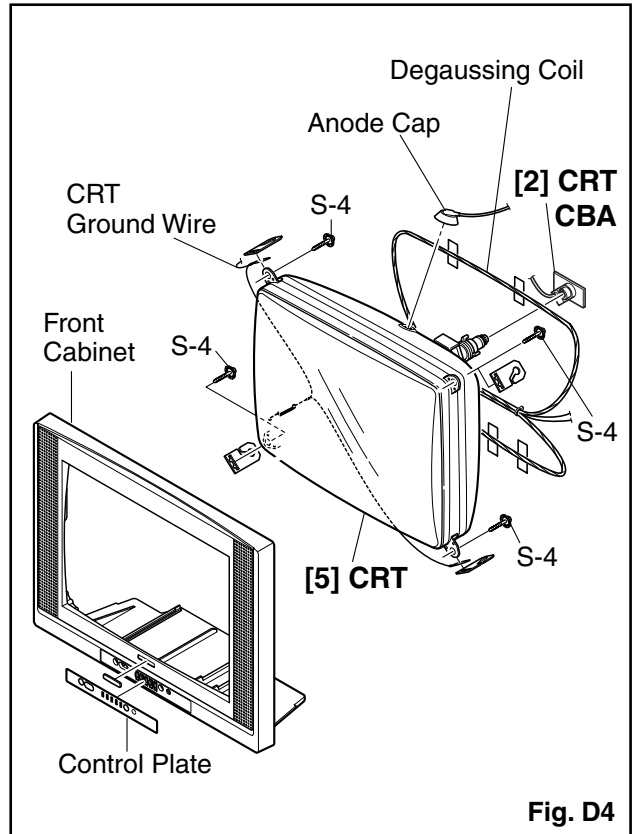
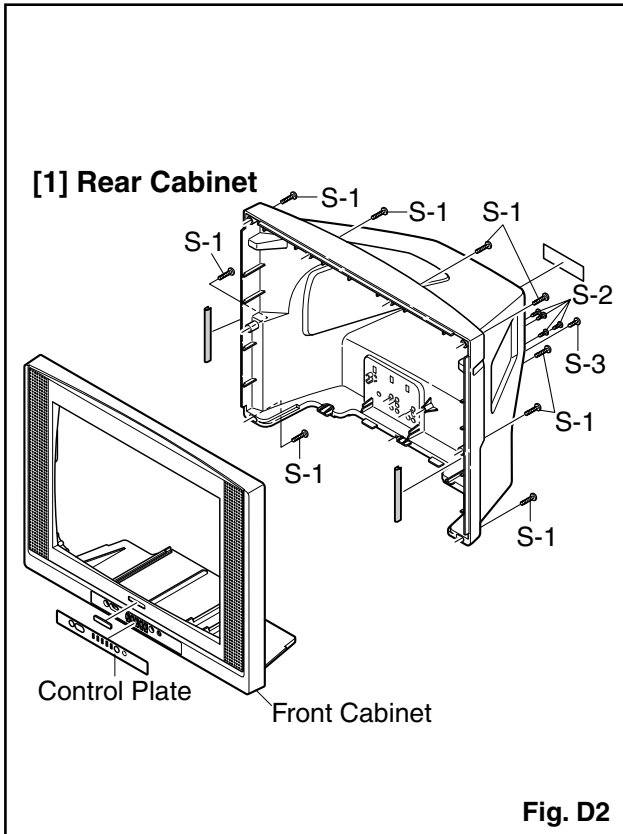
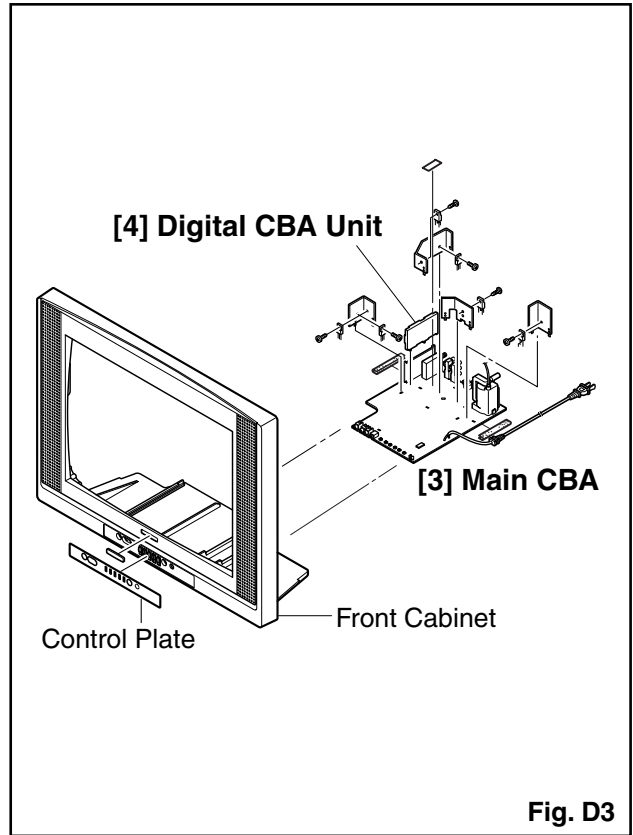
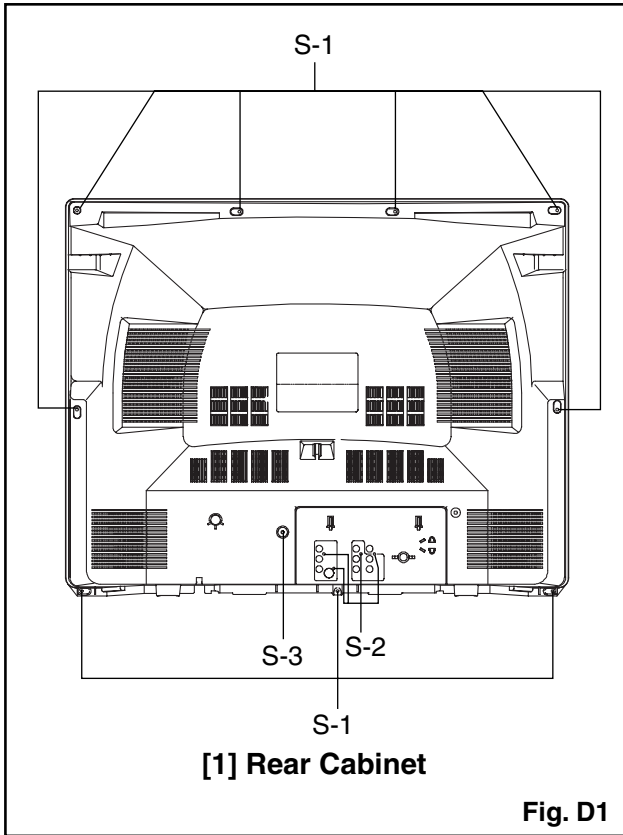

# TV Cable Wiring Diagram

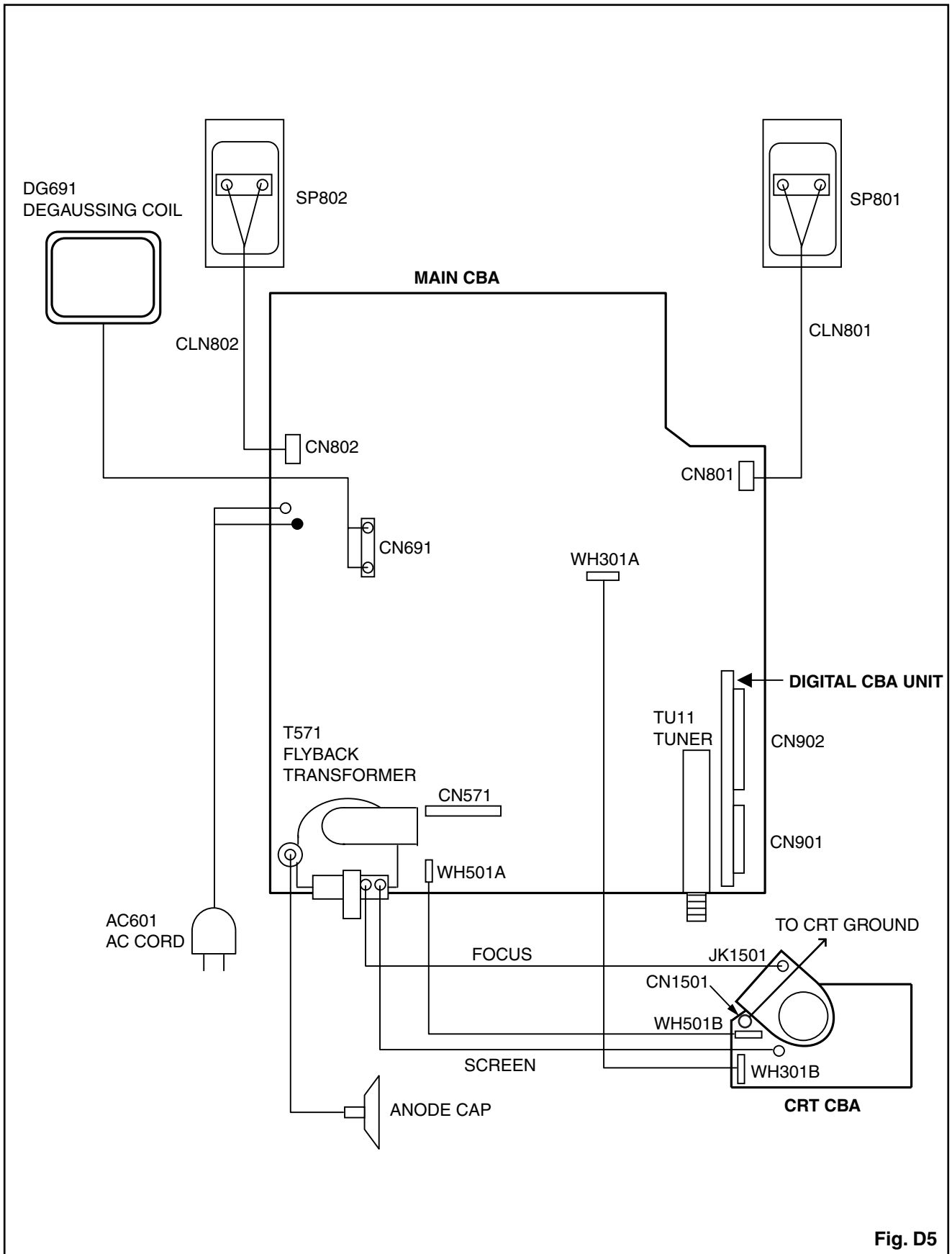

Fig. D5

# ELECTRICAL ADJUSTMENT INSTRUCTIONS

**General Note: “CBA” is abbreviation for “Circuit Board Assembly.”**

**Note:** Electrical adjustments are required after replacing circuit components and certain mechanical parts. It is important to perform these adjustments only after all repairs and replacements have been completed. Also, do not attempt these adjustments unless the proper equipment is available.

## Test Equipment Required

1. NTSC Pattern Generator (Color Bar W/White Window, Red Color, Dot Pattern, Gray Scale, Monoscope, Multi-Burst)
2. DC Voltmeter
3. Oscilloscope: Dual-trace with 10:1 probe, V-Range: 0.001~50 V/Div, F-Range: DC~AC-60 MHz
4. Plastic Tip Driver
5. Remote control unit: Part No. NE601UE
6. DC power supply 13.2V/5A

## How to make Service remote control unit:

1. Prepare normal remote control unit. (Part No. NE601UE)  
Remove 3 Screws from the back lid. (Fig. 1-1)

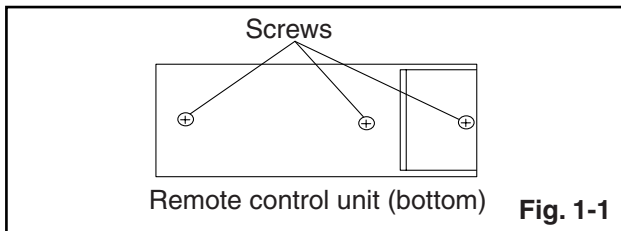

2. Add J1 (Jumper Wire) to the remote control CBA. (Fig. 1-2)

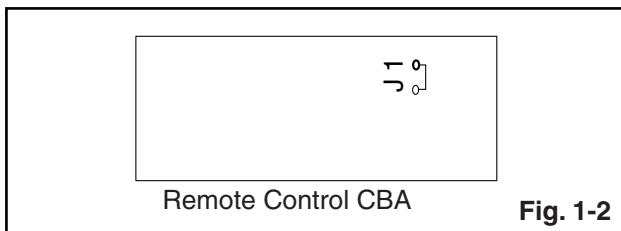

## How to enter the service mode:

### Service mode:

1. Use the service remote control unit.
2. Turn the power on. (Use main power on the TV unit.)
3. Press [SLEEP] button on the service remote control unit. Version of micro computer will display on the CRT. (M02-0.05 N2S \*\*)
4. Check the display on the lower left is “02” and if it is not “02” set it at “02” according to "Initial Setting" on page 5-2.

## 1. +B Adjustment

**Purpose:** To obtain correct operation.

**Symptom of Misadjustment:** The picture is dark and the unit does not operate correctly.

Test Point	Adj. Point	Mode	Input
TP601(+B) J371(GND)	VR661	---	---
<b>Tape</b>	<b>M. EQ.</b>	<b>Spec.</b>	
---	DC Voltmeter	+127±0.5 V DC.	

**Note:** TP601, J371(GND), VR661 --- Main CBA

1. Connect DC Volt Meter to TP601 and J371(GND).
2. Adjust VR661 so that the voltage of TP601 becomes +127±0.5 V DC.



## 2. Initial Setting

### General

1. Enter the Service mode. (See page 5-1.)
2. Press [VOL ▼] button on the service remote control unit. Display changes “C/D”, “7F”, “VIDEO”, “AV MEMO”, “STABLE SOUND”, “300”, “YUV MEMORY”, and “NO SIG BRT” cyclically when [VOL ▼] button is pressed.
3. To set the following each data value, press [CH ▲ / ▼] buttons on the service remote control unit.  
**7F---Set to “FF”.**  
**VIDEO---Set to “V1/V2/YUV”.**  
**AV MEMO---Set to “OFF”.**  
**STABLE SOUND---Set to “OFF”.**  
**7E DATA---Set to “300”.**  
**YUV MEMORY---Set to “OFF”.**  
**NO SIG BRT---Set to “0”.**

## 3. Setting for BRIGHT, CONTRAST, COLOR, S-COLOR, COMPONENT COLOR, TINT, V-TINT, S-TINT, COMPONENT TINT, SHARP, S-SHARP, and COMPONENT SHARP Data Values

### General

1. Enter the Service mode. (See page 5-1.)
2. Press [MENU] button on the service remote control unit. Display changes “BRT,” “CNT,” “CLR,” “S-CLR,” “C-CLR,” “TNT,” “V-TNT,” “S-TNT,” “C-TNT,” “SHARP,” “S-SRP,” and “C-SRP” cyclically when [MENU] button is pressed.

### CNT

1. Press [MENU] button on the service remote control unit. Then select “CONTRAST” (CNT) display.
2. Press [CH ▲ / ▼] buttons on the service remote control unit so that the value of “CONTRAST” (CNT) becomes 69.

### CLR

1. Press [MENU] button on the service remote control unit. Then select “COLOR” (CLR) display.
2. Press [CH ▲ / ▼] buttons on the service remote control unit so that the value of “COLOR” (CLR) becomes 73.

### S-CLR

1. Press [MENU] button on the service remote control unit. Then select “S-COLOR” (S-CLR) display.
2. Press [CH ▲ / ▼] buttons on the service remote control unit so that the value of “S-COLOR” (S-CLR) becomes 73.

### C-CLR

1. Press [MENU] button on the service remote control unit. Then select “COMPONENT COLOR” (C-CLR) display.
2. Press [CH ▲ / ▼] buttons on the service remote control unit so that the value of “COMPONENT COLOR” (C-CLR) becomes 59.

### TNT

1. Press [MENU] button on the service remote control unit. Then select “TINT” (TNT) display.
2. Press [CH ▲ / ▼] buttons on the service remote control unit so that the value of “TINT” (TNT) becomes 54.

### V-TNT

1. Press [MENU] button on the service remote control unit. Then select “V-TINT” (V-TNT) display.
2. Press [CH ▲ / ▼] buttons on the service remote control unit so that the value of “V-TINT” (V-TNT) becomes 59.

### S-TNT

1. Press [MENU] button on the service remote control unit. Then select “S-TINT” (S-TNT) display.
2. Press [CH ▲ / ▼] buttons on the service remote control unit so that the value of “S-TINT” (S-TNT) becomes 58.

### C-TNT

1. Press [MENU] button on the service remote control unit. Then select “COMPONENT TINT” (C-TNT) display.
2. Press [CH ▲ / ▼] buttons on the service remote control unit so that the value of “COMPONENT TINT” (C-TNT) becomes 63.

### SHARP

1. Press [MENU] button on the service remote control unit. Then select “SHARP” (SHARP) display.
2. Press [CH ▲ / ▼] buttons on the service remote control unit and select “42.”

### S-SRP

1. Press [MENU] button on the service remote control unit. Then select “S-SHARP” (S-SRP) display.
2. Press [CH ▲ / ▼] buttons on the service remote control unit and select “40.”

### C-SRP

1. Press [MENU] button on the service remote control unit. Then select “COMPONENT SHARP” (C-SRP) display.
2. Press [CH ▲ / ▼] buttons on the service remote control unit and select “45.”

**Note:** **BRIGHT** data value does not need to be adjusted at this moment.

## 4. H f<sub>0</sub> Adjustment

**Purpose:** To get correct horizontal frequency.

**Note:** Use service remote control unit.

1. To perform the H f<sub>0</sub> adjustment automatically, press [2] button on the service remote control unit.
2. If the adjustment value is not "4", press again [2] button on the service remote control unit. Then press [CH ▲ / ▼] buttons to set "4".
3. Turn the power off and on again. (Main Power button on the TV unit.)

## 5. Purity Check

1. Enter the Service mode. (See page 5-1.)
2. Press [7] button on the remote control unit. Each time pressing [7] button on the service remote control unit, display changes Red mode, Green mode, Blue mode, and White mode cyclically.
3. Select White mode.
4. Turn the power off and on again. (Main power button on the TV unit.)

## 6. SD Check Mode

1. Enter the Service mode. (See page 5-1.)
2. Press [1] button on the remote control unit. The unit enter the SD-Check mode.
3. The unit starts selecting the added channel from first channel according to the memorized CH ADD/DELL data and CATV/TV data in RAM.

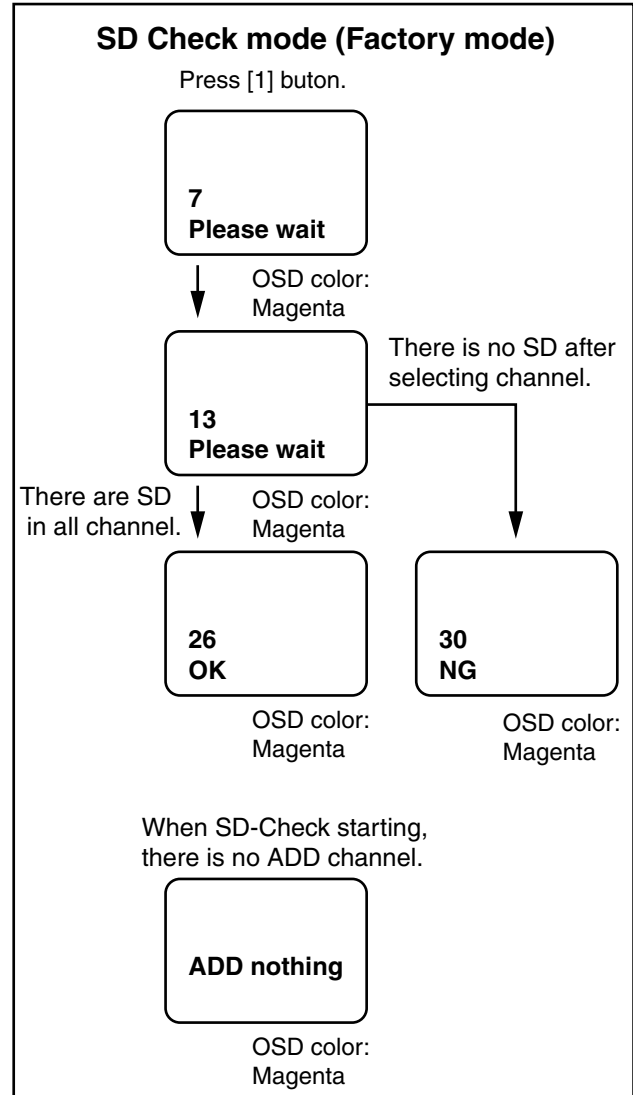

## 7. H. Position Adjustment

**Purpose:** To obtain correct horizontal position of screen image.

**Symptom of Misadjustment:** If H. Position is incorrect, horizontal position of image on the screen may not be properly displayed.

Test Point	Adj. Point	Mode	Input
---	[CH ▲ / ▼] buttons	RF	Monoscope
Tape	M. EQ.	Spec.	
---	Monoscope	90±5%	

**Note:** Use service remote control unit

1. Operate the unit for at least 20 minutes.
2. Enter the Service mode. (See page 5-1.)
3. Receive the monoscope pattern.
4. Press [8] button on the service remote control unit and select "H-S" mode. (Display change "H-S" and "H-P" cyclically when [8] button is pressed.)
5. Press [CH ▲ / ▼] buttons on the service remote control unit so that the monoscope pattern will be 90±5% of display size and the circle is round.
6. Turn the power off and on again. (Main power button on the TV unit.)

## 8. H. Size Adjustment

**Purpose:** To obtain correct horizontal size of screen image.

**Symptom of Misadjustment:** If H. Size is incorrect, horizontal size of image on the screen may not be properly displayed.

Test Point	Adj. Point	Mode	Input
---	[CH ▲ / ▼] buttons	RF	Monoscope
Tape	M. EQ.	Spec.	
---	Monoscope	90±5%	

**Note:** Use service remote control unit

1. Operate the unit for at least 20 minutes.
2. Enter the Service mode. (See Page 5-1.)
3. Receive the monoscope pattern.
4. Press [8] button on the service remote control unit and select "H-S" mode. (Display change "H-S" and "H-P" cyclically when [8] button is pressed.)
5. Press [CH ▲ / ▼] buttons on the service remote control unit so that the monoscope pattern will be 90±5% of display size and the circle is round.
6. Turn the power off and on again. (Main power button on the TV unit.)

## 9. V. Position Adjustment

**Purpose:** To obtain correct vertical width of screen image.

**Symptom of misadjustment:** If V. Position is incorrect, vertical height of image on the screen may not be properly displayed.

Test Point	Adj. Point	Mode	Input
---	[CH ▲ / ▼] buttons	RF	Monoscope
Tape	M. EQ.	Spec.	
---	Monoscope	See below.	

**Note:** Use service remote control unit

1. Operate the unit for at least 20 minutes.
2. Enter the Service mode. (See page 5-1.)
3. Receive the monoscope pattern.
4. Press [9] button on the service remote control unit and select "V-P" mode. (Display change "V-S" and "V-P" cyclically when [9] button is pressed.)
5. Press [CH ▲ / ▼] buttons on the service remote control unit so that the top and bottom of the monoscope pattern will be equal of each other.
6. Turn the power off and on again. (Main power button on the TV unit.)

## 10. V. Size Adjustment

**Purpose:** To obtain correct vertical width of screen image.

**Symptom of Misadjustment:** If V. Size is incorrect, vertical size of image on the screen may not be properly displayed.

Test Point	Adj. Point	Mode	Input
---	[CH ▲ / ▼] buttons	RF	Monoscope
Tape	M. EQ.	Spec.	
---	Monoscope	90±5%	

**Note:** Use service remote control unit.

1. Operate the unit for at least 20 minutes.
2. Enter the Service mode. (See page 5-1.)
3. Receive the monoscope pattern.
4. Press [9] button on the service remote control unit and select "V-S" mode. (Display changes "V-S" and "V-P" cyclically when [9] button is pressed.)
5. Press [CH ▲ / ▼] buttons on the service remote control unit so that the monoscope pattern will be 90±5% of display size and the circle is round.
6. Turn the power off and on again. (Main power button on the TV unit.)

## 11. Cut-off Adjustment

**Purpose:** To adjust the beam current of R, G, B, and screen voltage.

**Symptom of Misadjustment:** White color may be reddish, greenish or bluish.

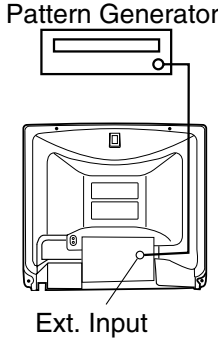
Test Point	Adj. Point	Mode	Input
---	Screen-Control [CH ▲ / ▼] buttons	RF	Black Raster
Tape	M. EQ.	Spec.	
---	Pattern Generator	See Reference Notes below.	
Figure			
 <p>Pattern Generator</p> <p>Ext. Input</p>			

**Fig. 2**

**Note:** Screen Control FBT --- Main CBA  
 FBT = Fly Back Transformer  
 Use service remote control unit

1. Degauss the CRT and allow CRT to operate for 20 minutes before starting the alignment.
2. Input the Black Raster Signal from RF Input.
3. Enter the Service mode. (See page 5-1.)
4. Press [VOL ▼] button on the service remote control unit and select "C/D" mode. (Display changes "C/D", "7F", "VIDEO", "AV MEMO", "STABLE SOUND", "300", "YUV MEMORY", and "NO SIG BRT" cyclically when [VOL ▼] button is pressed.) then press "1." The display will momentarily show "CUT OFF R" (R= Red). Now there should be a horizontal line across the center of the picture tube. If needed gradually turn the screen control on the flyback, clockwise until the horizontal line appears. Adjust the Red Cut off by pressing [CH ▲ / ▼] buttons. Proceed to Step 5 when the Red Cut off adjustment is done.
5. Press [2] button. The display will momentarily show "CUT OFF G" (G = Green). Adjust the Green Cut off by pressing [CH ▲ / ▼] buttons. Proceed to step 6 when the Green Cut off adjustment is done.
6. Press [3] button. The display will momentarily show "CUT OFF B" (B = Blue). Adjust the Blue cut off by pressing [CH ▲ / ▼] buttons. When done

with steps 4, 5 and 6 the horizontal line should be pure white if not, then attempt the Cut off adjustment again.

## 12. White Balance Adjustment

**Purpose:** To mix red, green and blue beams correctly for pure white.

**Symptom of Misadjustment:** White becomes bluish or reddish.

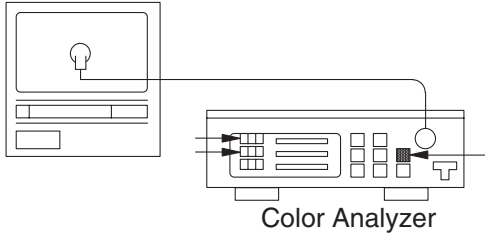
Test Point	Adj. Point	Mode	Input
Screen	[CH ▲ / ▼] buttons	RF	White Raster (APL 100%)
Tape	M. EQ.	Spec.	
---	Pattern Generator, Color analyzer	See below	
Figure			
 <p>Color Analyzer</p>			

**Fig. 3**

**Note:** Use service remote control unit

1. Operate the unit more than 20 minutes.
2. Face the unit to east. Degauss the CRT using Degaussing Coil.
3. Input the White Raster (APL 100%).
4. Set the color analyzer to the CHROMA mode and after zero point calibration, bring the optical receptor to the center on the tube surface (CRT).
5. Enter the Service mode. (See page 5-1.) Press [VOL ▼] button on the service remote control unit and select "C/D" mode. (Display changes "C/D", "7F", "VIDEO", "AV MEMO", "STABLE SOUND", "300", "YUV MEMORY", and "NO SIG BRT" cyclically when [VOL ▼] button is pressed.) then Press [8] button on the service remote control Unit.
6. Press [4] button on the service remote control unit for Red adjustment. Press [5] button on the service remote control unit for Blue adjustment.
7. In each color mode, Press [CH ▲ / ▼] buttons to adjust the values of color.
8. Adjusting Red and Blue color so that the temperature becomes 9200K (x: 286 / y: 294)±3%.

9. At this time, Re-check that Horizontal line is white. If not, Re-adjust Cut-off Adjustment until the Horizontal Line becomes pure white.
10. Turn off and on again to return to normal mode. Receive APL 100% white signal and Check Chroma temperatures become 9200K (x: 286 / y: 294)±3%.

**Note:** Confirm that Cut Off Adj. is correct after this adjustment, and attempt Cut Off Adj. if needed.

### 13. U-Offset

1. In VIDEO mode (white 50%) of V1 or V2, press [3] button on the service remote control unit and select "U-Offset" mode. (Display change "U-Offset", "V-Offset", "U-Offset YUV" and "V-Offset YUV" cyclically when [3] button pressed.)
2. Press [VOL ▲ / ▼] button on the service remote control unit and select "U-Offset (Cyan)" mode.
3. Check the waveform of the base of Q1531 on the CRT CBA with the oscilloscope.
4. Press [VOL ▲ / ▼] button on the service remote control unit and select "U-Offset (Magenta)" mode.
5. Press [CH ▲ / ▼] buttons so that the waveform of the "U-Offset (Magenta)" mode is equal to the waveform of the "U-Offset (Cyan)" mode.

### 14. V-Offset

1. In VIDEO mode (white 50%) of V1 or V2, press [3] button on the service remote control unit and select "V-Offset" mode. (Display change "U-Offset", "V-Offset", "U-Offset YUV" and "V-Offset YUV" cyclically when [3] button pressed.)
2. Press [VOL ▲ / ▼] button on the service remote control unit and select "V-Offset (Cyan)" mode.
3. Check the waveform of the base of Q1511 on the CRT CBA with the oscilloscope.
4. Press [VOL ▲ / ▼] button on the service remote control unit and select "V-Offset (Magenta)" mode.
5. Press [CH ▲ / ▼] buttons so that the waveform of the "V-Offset (Magenta)" mode is equal to the waveform of the "V-Offset (Cyan)" mode.

### 15. U-Offset YUV

1. In VIDEO mode (white 50%) of YUV, press [3] button on the service remote control unit and select "U-Offset YUV" mode. (Display change "U-Offset", "V-Offset", "U-Offset YUV" and "V-Offset YUV" cyclically when [3] button pressed.)
2. Press [VOL ▲ / ▼] button on the service remote control unit and select "U-Offset YUV (Cyan)" mode.
3. Check the waveform of the base of Q1531 on the CRT CBA with the oscilloscope.

4. Press [VOL ▲ / ▼] button on the service remote control unit and select "U-Offset YUV (Magenta)" mode.
5. Press [CH ▲ / ▼] buttons so that the waveform of the "U-Offset YUV (Magenta)" mode is equal to the waveform of the "U-Offset YUV (Cyan)" mode.

### 16. V-Offset YUV

1. In VIDEO mode (white 50%) of YUV, press [3] button on the service remote control unit and select "V-Offset YUV" mode. (Display change "U-Offset", "V-Offset", "U-Offset YUV" and "V-Offset YUV" cyclically when [3] button pressed.)
2. Press [VOL ▲ / ▼] button on the service remote control unit and select "V-Offset YUV (Cyan)" mode.
3. Check the waveform of the base of Q1511 on the CRT CBA with the oscilloscope.
4. Press [VOL ▲ / ▼] button on the service remote control unit and select "V-Offset YUV (Magenta)" mode.
5. Press [CH ▲ / ▼] buttons so that the waveform of the "V-Offset YUV (Magenta)" mode is equal to the waveform of the "V-Offset YUV (Cyan)" mode.

## 17. Sub-Brightness Adjustment

**Purpose:** To get proper brightness.

**Symptom of Misadjustment:** If Sub-Brightness is incorrect, proper brightness cannot be obtained by adjusting the Brightness Control.

Test Point	Adj. Point	Mode	Input
---	[CH ▲ / ▼] buttons	RF	IQW
<b>Tape</b>	<b>M. EQ.</b>	<b>Spec.</b>	
---	Pattern Generator	See below	

**Figure**

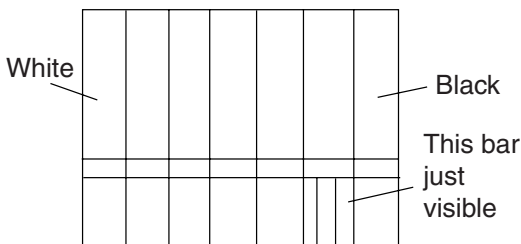

**Fig. 4**

**Note:** IQW Setup level --- 7.5 IRE

Use service remote control unit

1. Enter the Service mode. (See page 5-1.) Then input IQW signal from RF Input.
2. Press [MENU] button on the service remote control unit and Select "BRT" mode. (Display changes "BRT," "CNT," "CLR," "S-CLR," "C-CLR," "TNT," "V-TNT," "S-TNT," "C-TNT," "SHARP," "S-SRP," and "C-SRP" cyclically when [MENU] button is pressed.) Press [CH ▲ / ▼] buttons so that the bar is just visible (See above figure).
3. Turn the power off and on again. (Main power button on the TV unit.)

## 18. Focus Adjustment

**Purpose:** Set the optimum Focus.

**Symptom of Misadjustment:** If Focus Adjustment is incorrect, blurred images are shown on the display.

Test Point	Adj. Point	Mode	Input
---	Focus Control	---	Monoscope
<b>Tape</b>	<b>M. EQ.</b>	<b>Spec.</b>	
---	Pattern Generator	See below	

**Note:** Focus VR (FBT) --- Main CBA,  
FBT = Fly Back Transformer

1. Operate the unit more than 30 minutes.
2. Face the unit to the East and Degauss the CRT using Degaussing Coil.
3. Input the Monoscope Pattern.
4. Adjust the Focus Control on the FBT to obtain clear picture.

**The following adjustments normally are not attempted in the field. Only when replacing the CRT then adjust as a preparation.**

## 19. Purity Adjustment

**Purpose:** To obtain pure color.

**Symptom of Misadjustment:** If Color Purity Adjustment is incorrect, large areas of color may not be properly displayed.

Test Point	Adj. Point	Mode	Input
---	Deflection Yoke Purity Magnet	---	Red Color
Tape	M. EQ.	Spec.	
---	Pattern Generator	See below	

**Figure**

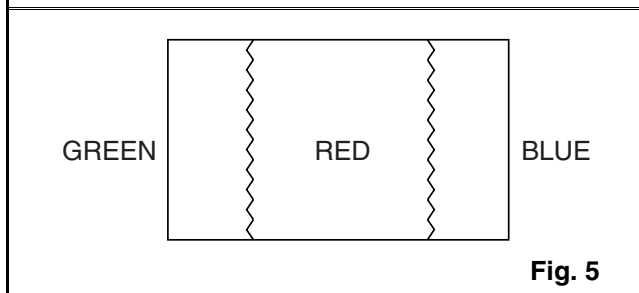
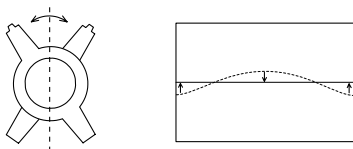

**Fig. 5**

1. Set the unit facing east.
2. Operate the unit for over 30 minutes before adjusting.
3. Fully degauss the unit using an external degaussing coil.
4. Loosen the screw on the Deflection Yoke Clamper and pull the Deflection Yoke back away from the screen. (See Fig. 6)
5. Loosen the Ring Lock and adjust the Purity Magnets so that a red is obtained at the center of the screen. Tighten Ring Lock. (See Fig. 5,6)
6. Slowly push the Deflection Yoke toward bell of CRT and set it where a uniform red field is obtained.
7. Tighten the clamp screw on the Deflection Yoke.

## 20. VRS Adjustment

1. Connect Oscilloscope and get the cross hatch pattern.
2. Adjust the two magnets for VRS adjustment like the below figure so that the cross hatch pattern becomes flat.



## 21. Convergence Adjustment

**Purpose:** To obtain proper convergence of red, green and blue beams.

**Symptom of Misadjustment:** If Convergence Adjustment is incorrect, the edge of white letters may have color edges.

Test Point	Adj. Point	Mode	Input
---	C.P. Magnet (RB) C.P. Magnet (RB-G) Deflection Yoke	---	Dot Pattern or Crosshatch
Tape	M. EQ.	Spec.	
---	Pattern Generator	See below	

**Figure**

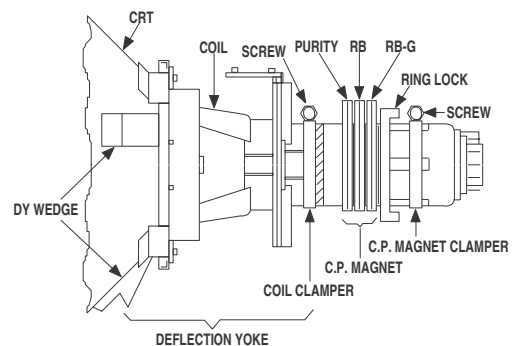

**Fig. 6**

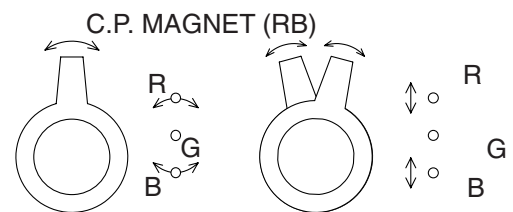

**Fig. 7**

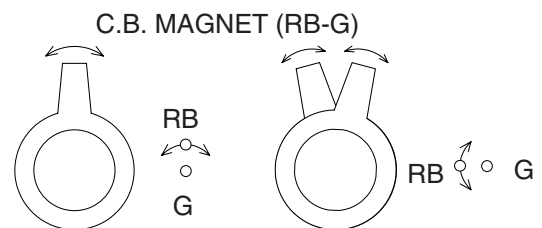

**Fig. 8**

1. Loosen the Ring Lock and align red with blue dots or Crosshatch at the center of the screen by rotating (RB) C.P. Magnets. (See Fig. 7)
2. Align red / blue with green dots at the center of the screen by rotating (RB-G) C.P. Magnet. (See Fig. 8)
3. Paintlock the C.P. Magnets after adjustment.

4. Remove the DY Wedges and slightly tilt the Deflection Yoke horizontally and vertically to obtain the best overall convergence.
5. Fix the Deflection Yoke by carefully inserting the DY Wedges between CRT and Deflection Yoke.

## 22. Yh, Yv, Xv Adjustment

1. Adjust the volume of Deflection Yoke(Yh, Yv, Xv) to get good convergence.

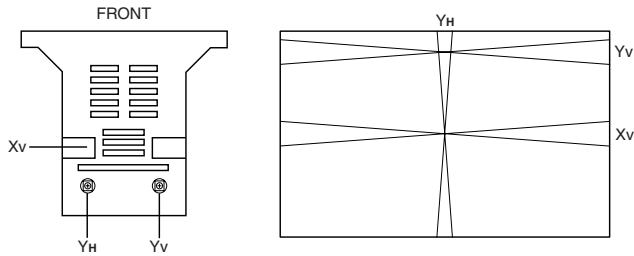

## 23. Software Reset

To reset software, press [5] button on the remote control unit for at least 5 seconds after pressing [CH RETURN] button on the remote control unit.



# HOW TO INITIALIZE THE ANALOG/DIGITAL COLOR TELEVISION

To put the program back at the factory-default, initialize the Analog/Digital Color Television as the following procedure.

1. Use the service remote control unit.
2. Turn the power on. (Use main power on the TV unit.)
3. Press [SLEEP] button on the service remote control unit to enter the Service mode. (Refer to "How to enter the Service mode" on page 5-1.)
4. Press [VOL ▼] button on the service remote control unit twice, and confirm that OSD indication is "7F = FF." If needed, set it to become "7F = FF" by pressing [CH ▲ / ▼] buttons on the service remote control unit.
5. Confirm that OSD indication on the four corners on TV screen changes from on and off light indication to red by pressing a [INFO] button. (It takes one or two seconds.)
6. Turn the power off by pressing main power button on the TV unit, and unplug the AC cord from the AC outlet.

# BLOCK DIAGRAMS

## System Control Block Diagram

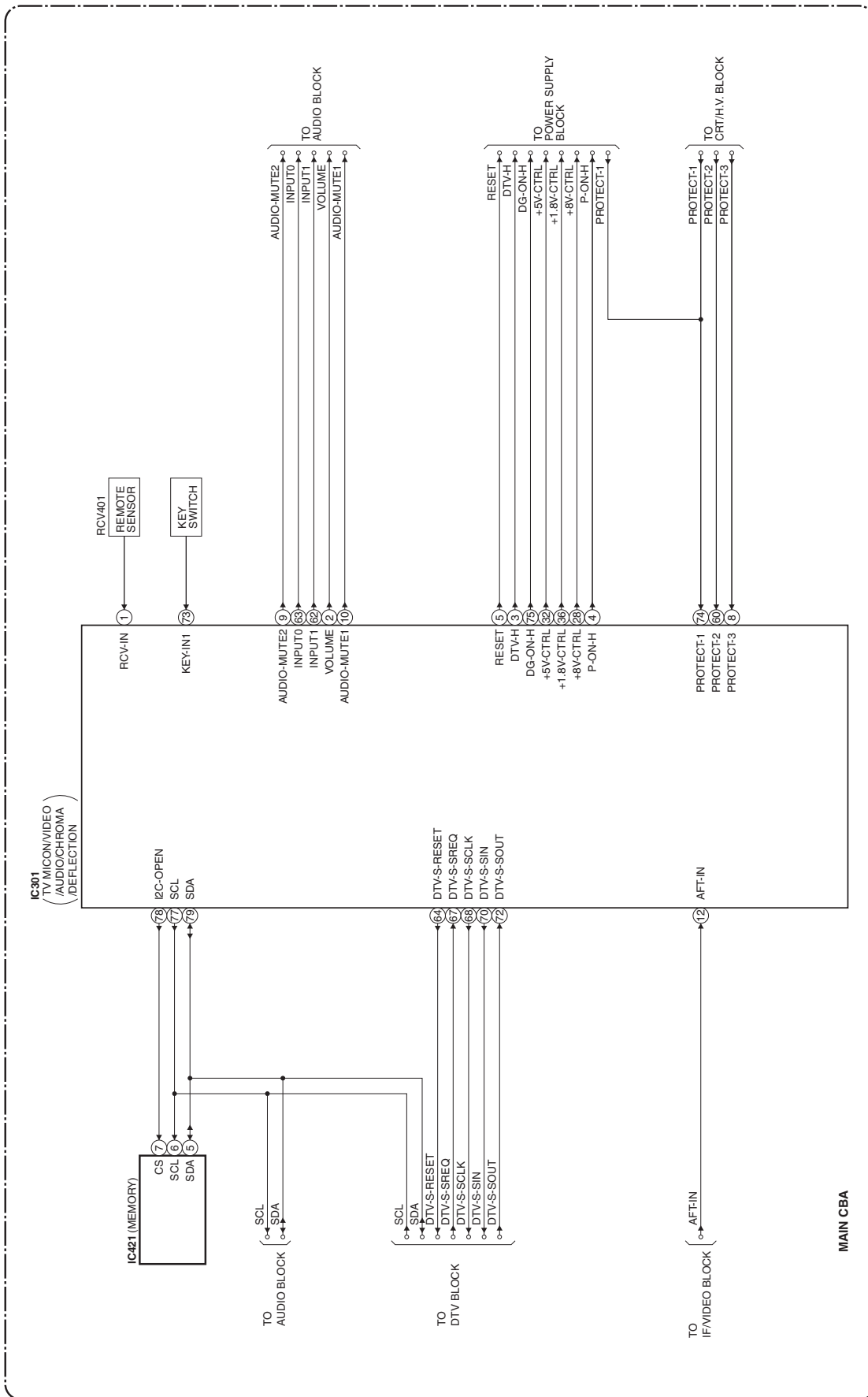

# DTV Block Diagram

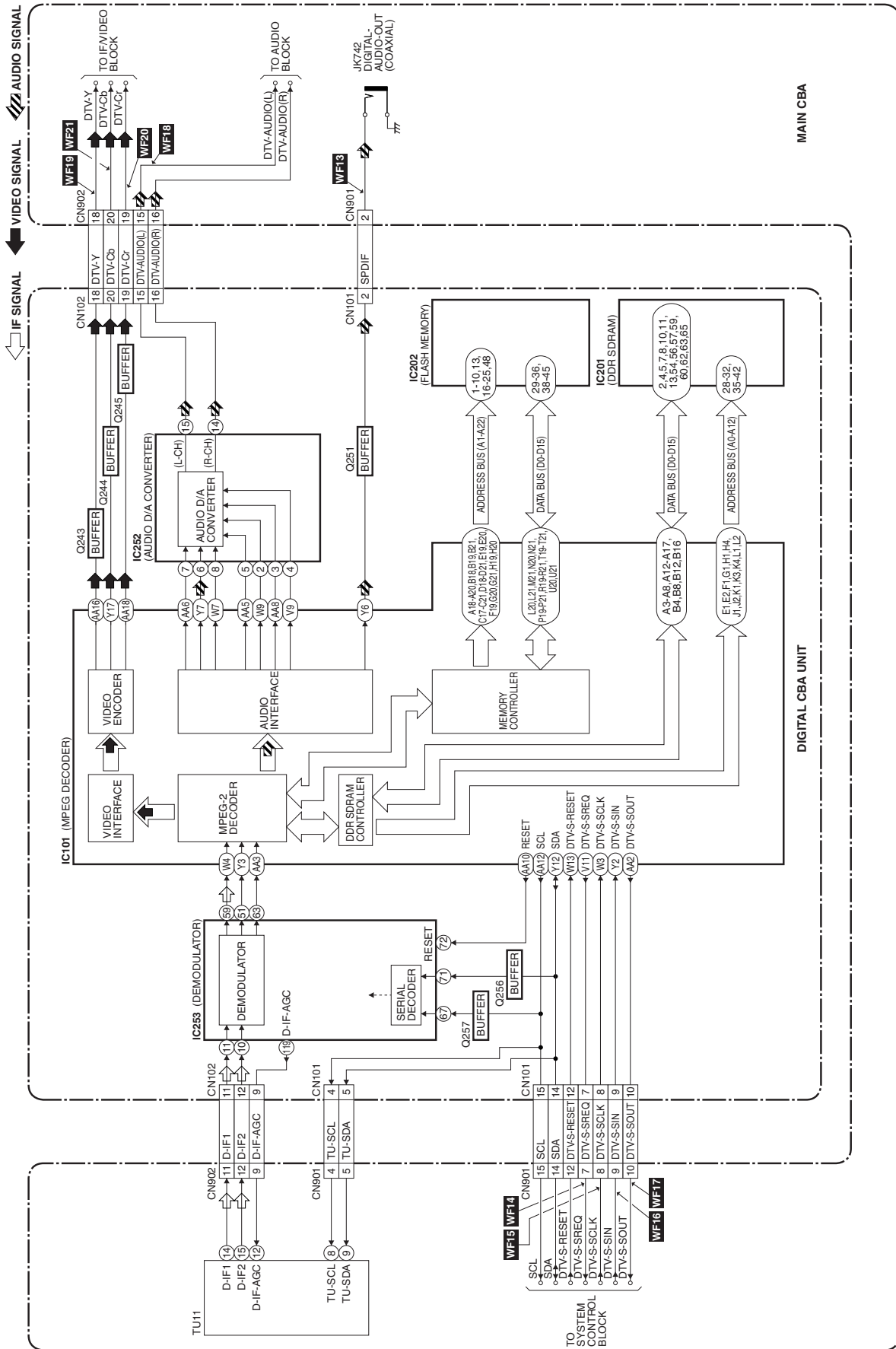

# IF/Video Block Diagram

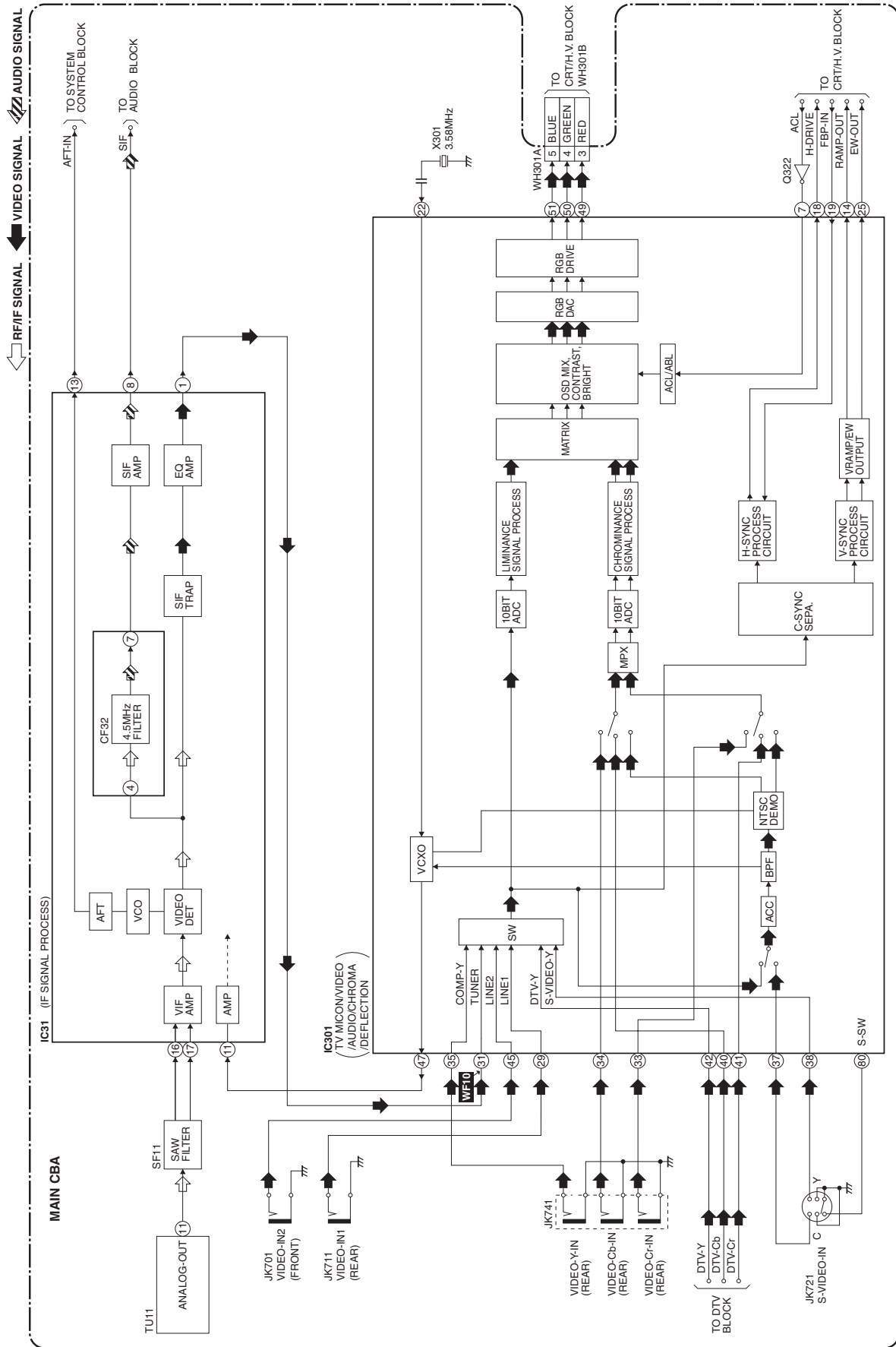

# Audio Block Diagram

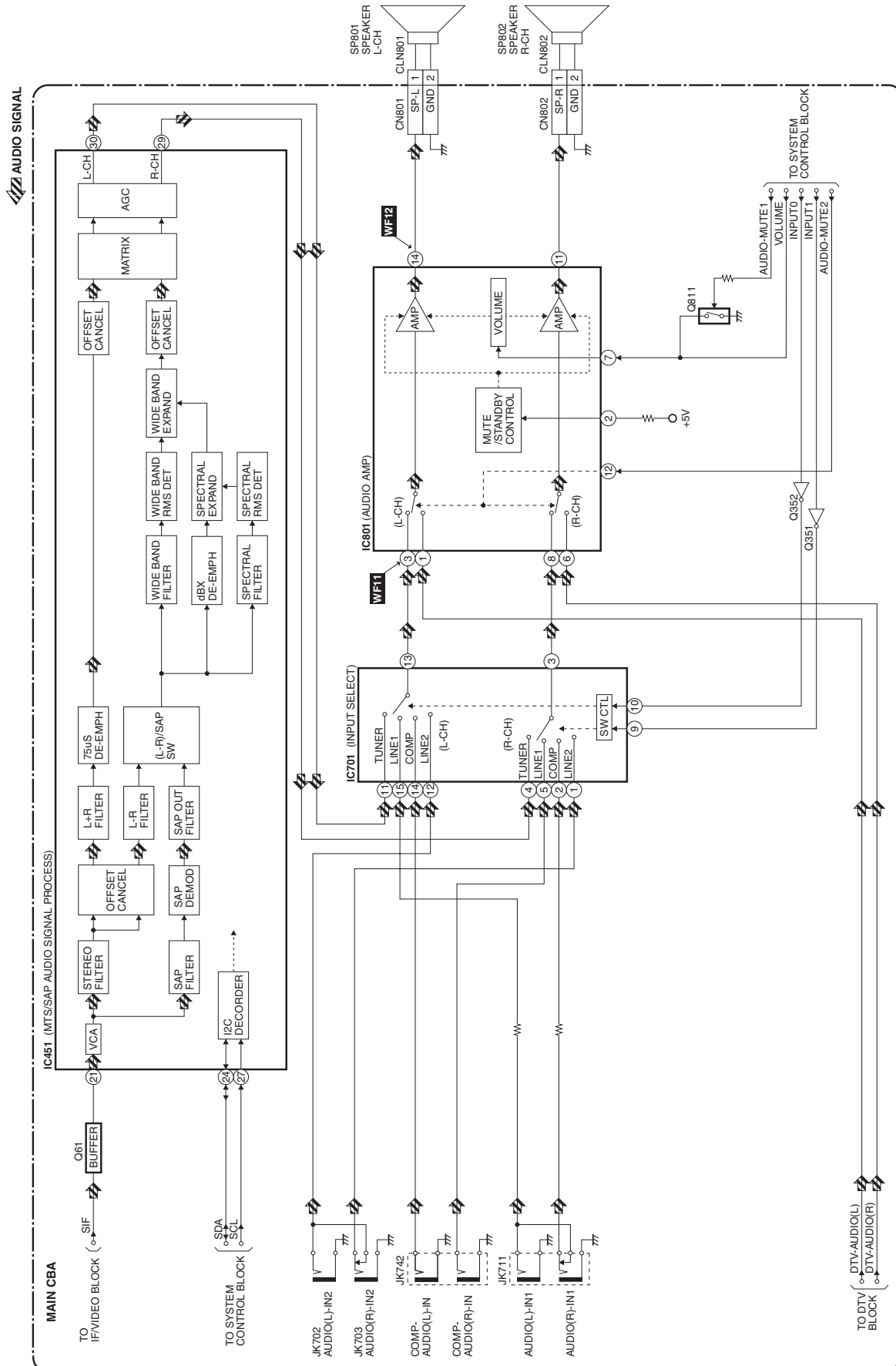



# Power Supply Block Diagram

## CAUTION !

Fixed voltage (or Auto voltage selectable) power supply circuit is used in this unit.  
If Main Fuse (F601) is blown, check to see that all components in the power supply circuit are not defective before you connect the AC plug to the AC power supply.  
Otherwise it may cause some components in the power supply circuit to fail.



**CAUTION ! :** For continued protection against risk of fire, replace only with same type 4 A, 125V fuse.  
**ATTENTION :** Utiliser un fusible de rechange de même type de 4A, 125V.

## NOTE:

The voltage for parts in hot circuit is measured using hot GND as a common terminal.

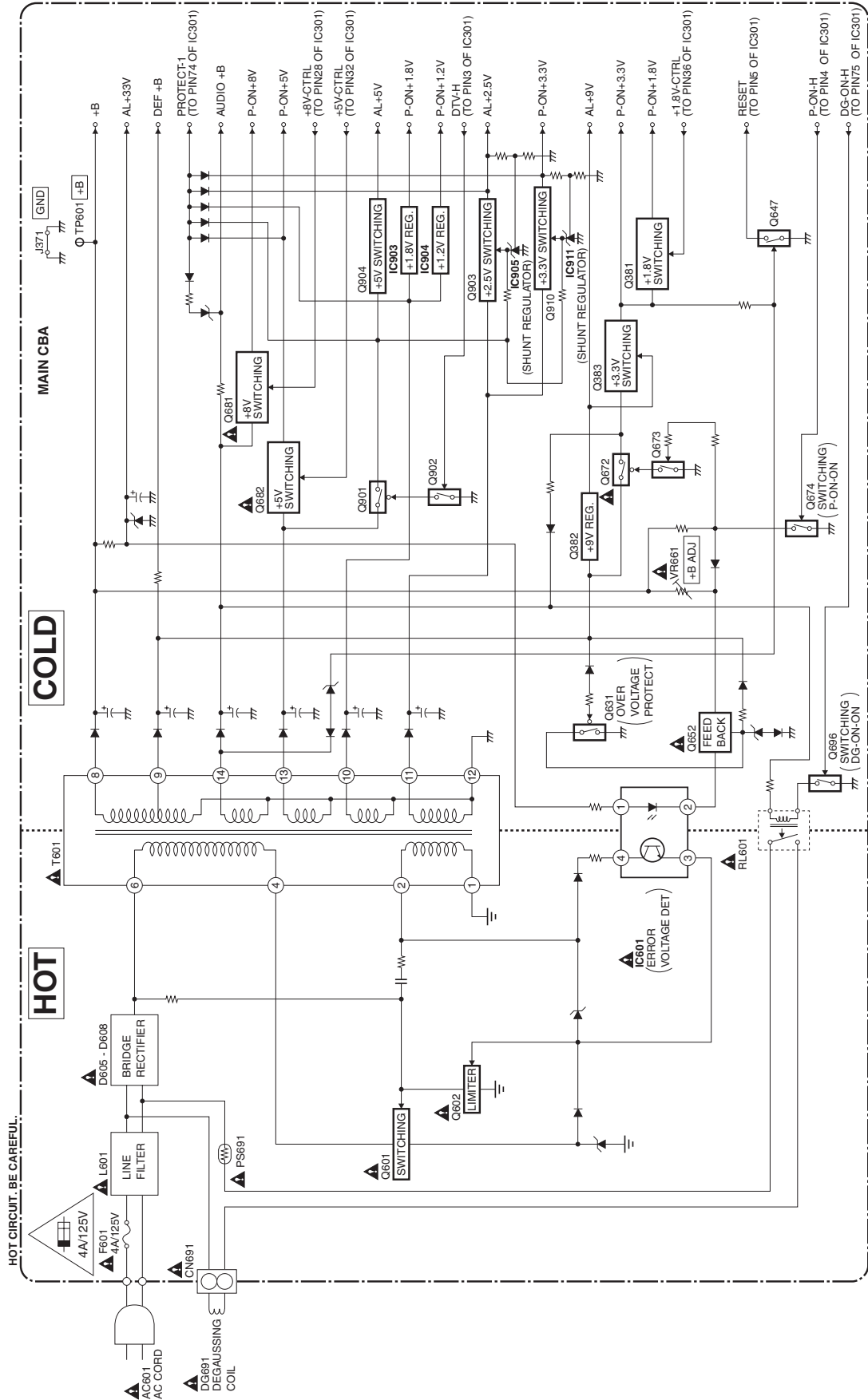

# SCHEMATIC DIAGRAMS / CBA'S AND TEST POINTS

## Standard Notes

Many electrical and mechanical parts in this chassis have special characteristics. These characteristics often pass unnoticed and the protection afforded by them cannot necessarily be obtained by using replacement components rated for higher voltage, wattage, etc. Replacement parts that have these special safety characteristics are identified in this manual and its supplements; electrical components having such features are identified by the mark “▲” in the schematic diagram and the parts list. Before replacing any of these components, read the parts list in this manual carefully. The use of substitute replacement parts that do not have the same safety characteristics as specified in the parts list may create shock, fire, or other hazards.

## Notes:

1. Do not use the part number shown on these drawings for ordering. The correct part number is shown in the parts list, and may be slightly different or amended since these drawings were prepared.
2. All resistance values are indicated in ohms ( $K = 10^3$ ,  $M = 10^6$ ).
3. Resistor wattages are 1/4W or 1/6W unless otherwise specified.
4. All capacitance values are indicated in  $\mu F$  ( $P = 10^{-6} \mu F$ ).
5. All voltages are DC voltages unless otherwise specified.

## Note of Capacitors:

ML --- Mylar Cap. PP --- Metallized Film Cap. SC --- Semiconductor Cap. L --- Low Leakage type

## Temperature Characteristics of Capacitors are noted with the following:

B ---  $\pm 10\%$  CH ---  $0 \pm 60$  ppm/ $^{\circ}C$  CSL ---  $+350 \sim 1000$  ppm/ $^{\circ}C$

## Tolerance of Capacitors are noted with the following:

Z ---  $+80 \sim 20\%$

## Note of Resistors:

CEM --- Cement Res. MTL --- Metal Res. F --- Fuse Res.

## Capacitors and transistors are represented by the following symbols.

### CBA Symbols

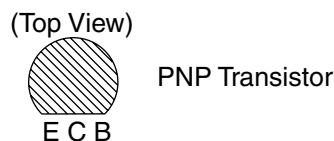
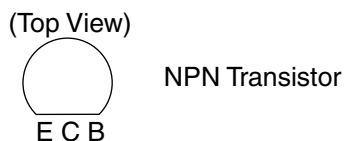
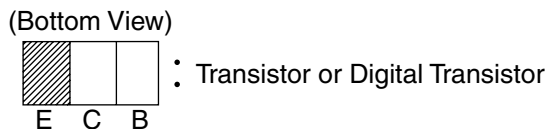
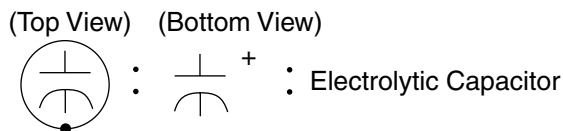

### Schematic Diagram Symbols

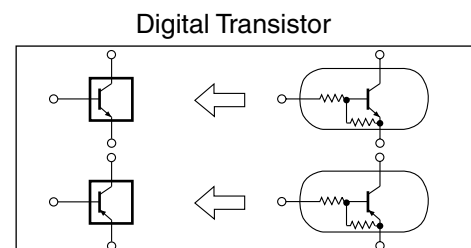



## LIST OF CAUTION, NOTES, AND SYMBOLS USED IN THE SCHEMATIC DIAGRAMS ON THE FOLLOWING PAGES:

### 1. CAUTION:

**CAUTION:** FOR CONTINUED PROTECTION AGAINST RISK OF FIRE, REPLACE ONLY WITH SAME TYPE\_A,\_V FUSE.

**ATTENTION:** UTILISER UN FUSIBLE DE RECHANGE DE MÊME TYPE DE\_A,\_V.

### 2. CAUTION:

Fixed Voltage (or Auto voltage selectable) power supply circuit is used in this unit.

If Main Fuse (F601) is blown, first check to see that all components in the power supply circuit are not defective before you connect the AC plug to the AC power supply. Otherwise it may cause some components in the power supply circuit to fail.

### 3. Note:

- Do not use the part number shown on the drawings for ordering. The correct part number is shown in the parts list, and may be slightly different or amended since the drawings were prepared.
- To maintain original function and reliability of repaired units, use only original replacement parts which are listed with their part numbers in the parts list section of the service manual.

### 4. Voltage indications on the schematics are as shown below:

Plug the TV power cord into a standard AC outlet.:

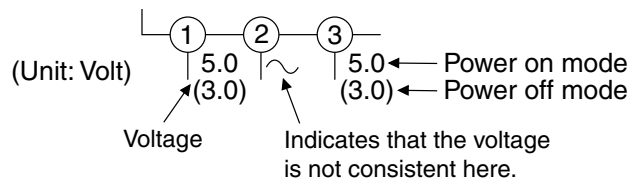

### 5. How to read converged lines

1-D3  
 Distinction Area  
 Line Number  
 (1 to 3 digits)

Examples:

- "1-D3" means that line number "1" goes to the line number "1" of the area "D3".
- "1-B1" means that line number "1" goes to the line number "1" of the area "B1".

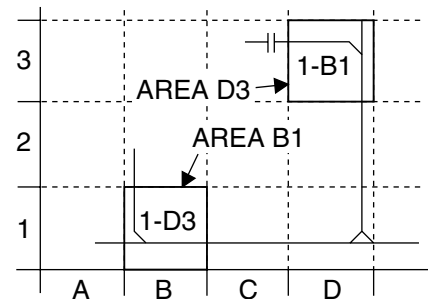

### 6. Test Point Information

 : Indicates a test point with a jumper wire across a hole in the PCB.

 : Used to indicate a test point with a component lead on foil side.

 : Used to indicate a test point with no test pin.

 : Used to indicate a test point with a test pin.



# Main 2/5 Schematic Diagram

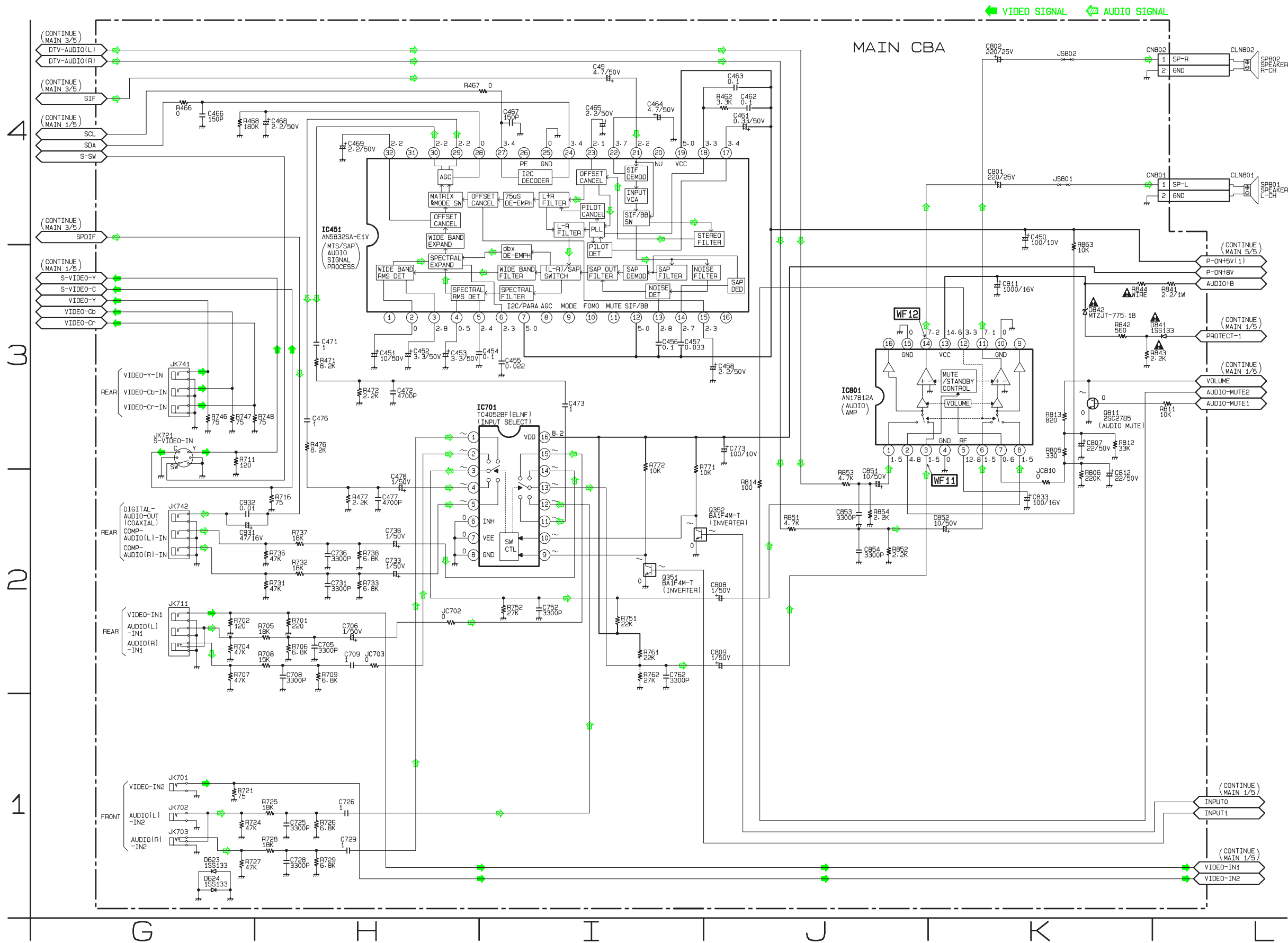

# Main 3/5 Schematic Diagram

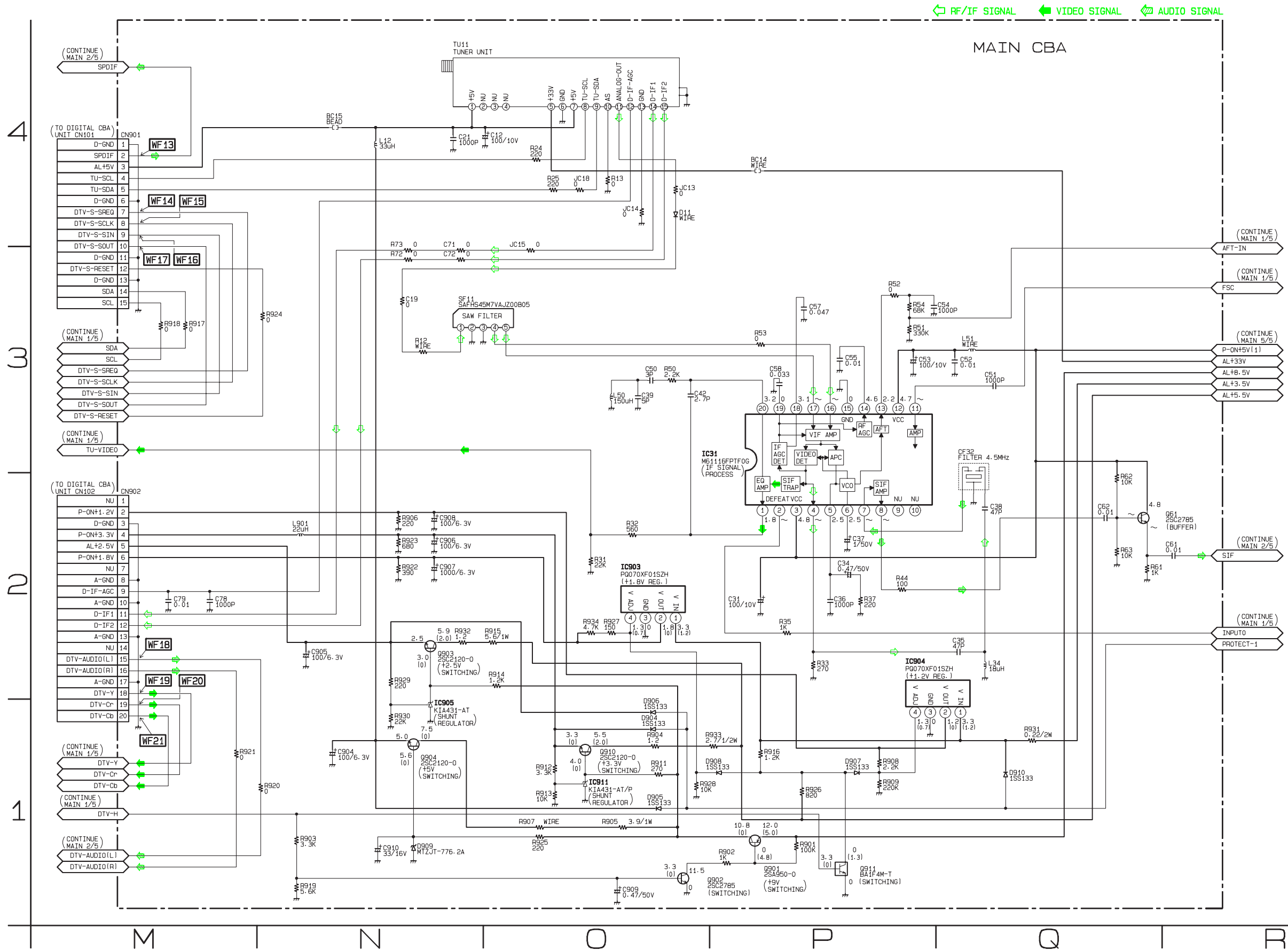

# Main 4/5 & CRT Schematic Diagram

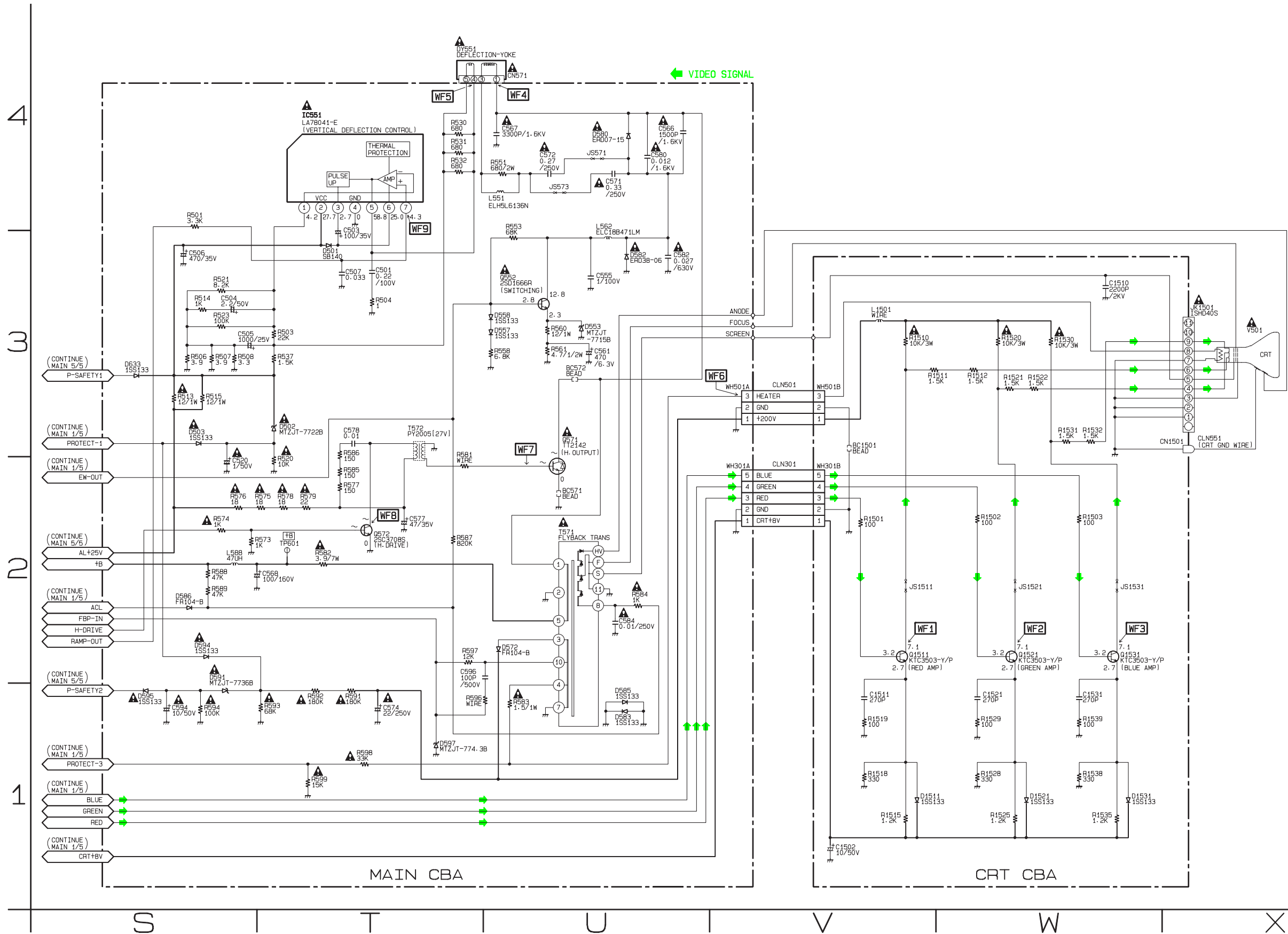

# Main 5/5 Schematic Diagram

## CAUTION !

Fixed voltage (or Auto voltage selectable) power supply circuit is used in this unit.  
If Main Fuse (F601) is blown, check to see that all components in the power supply circuit are not defective before you connect the AC plug to the AC power supply.  
Otherwise it may cause some components in the power supply circuit to fail.

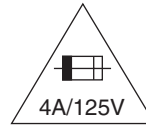

**CAUTION ! :** For continued protection against risk of fire, replace only with same type 4 A, 125V fuse.  
**ATTENTION :** Utiliser un fusible de rechange de même type de 4A, 125V.

## NOTE:

The voltage for parts in hot circuit is measured using hot GND as a common terminal.

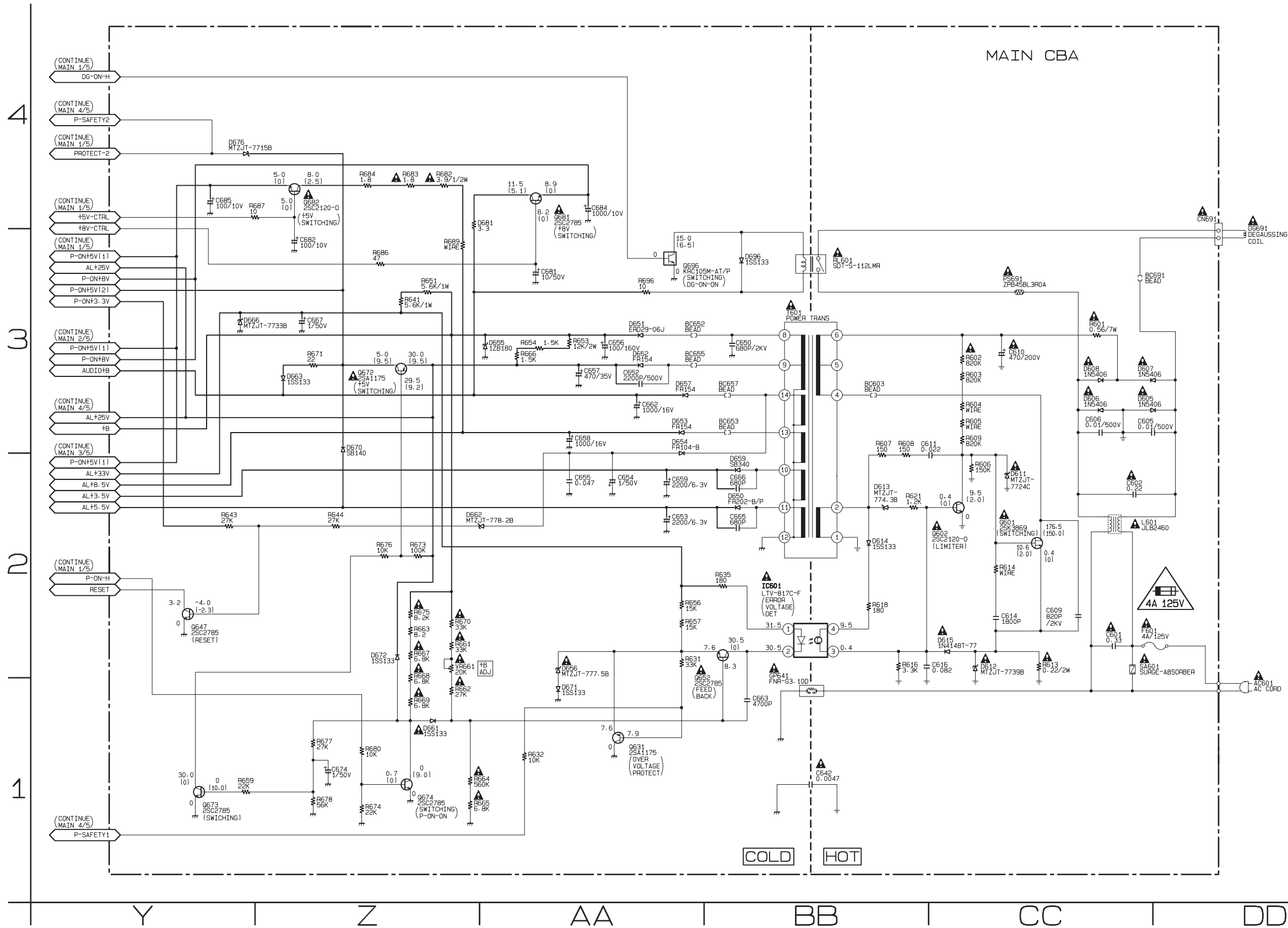

# Digital 1/3 Schematic Diagram

**\*1 NOTE:**

1. The order of pins shown in this diagram is different from that of actual IC101.
2. IC101 is divided into two and shown as IC101 (1/2) ~ IC101 (2/2) in this Digital Schematic Diagram Section.

IF SIGNAL VIDEO SIGNAL AUDIO SIGNAL

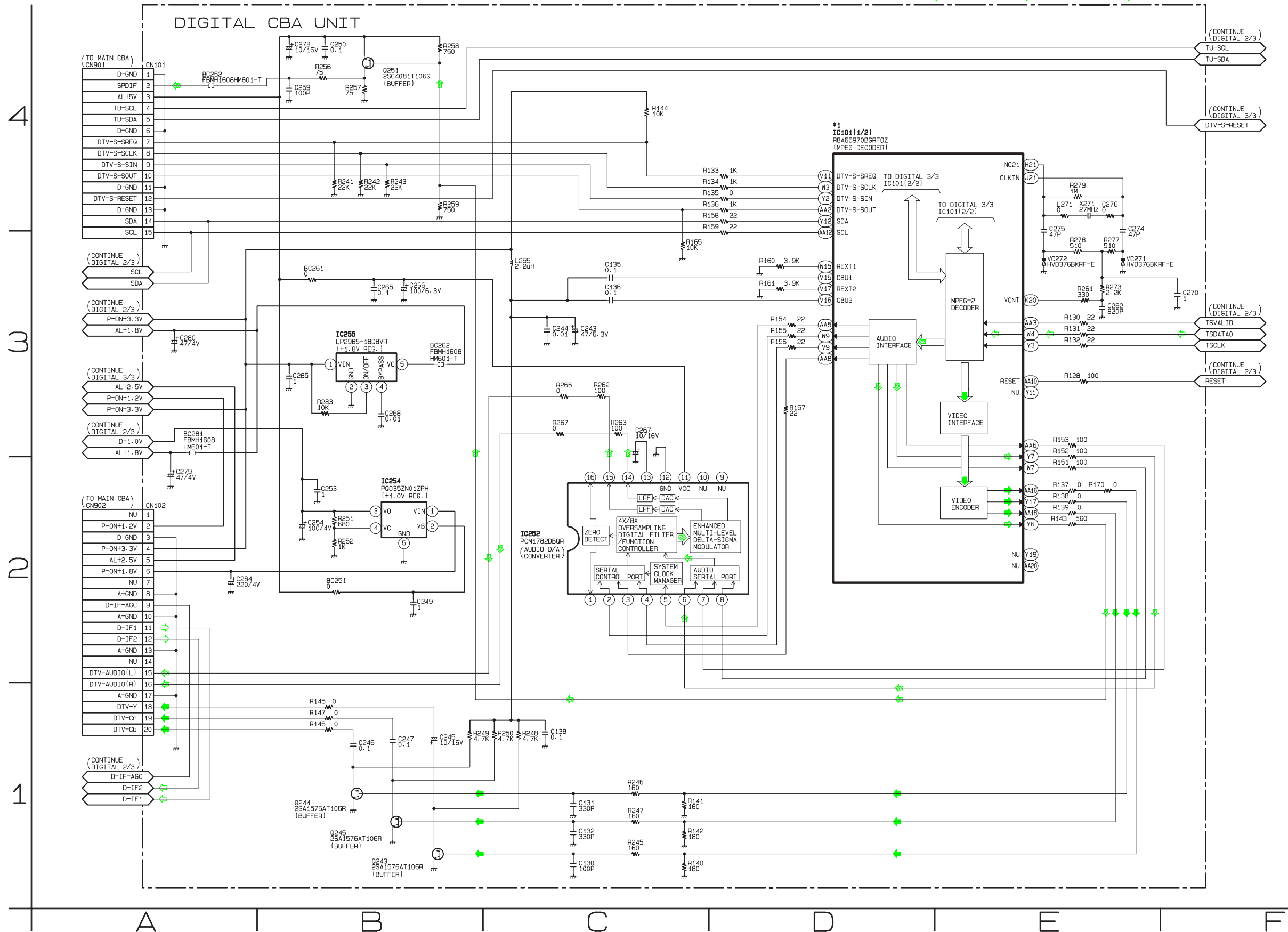

## VOLTAGE CHART

CN101

Pin No.	Voltage
1	0
2	1.5
3	5.0
4	3.4
5	3.4
6	0
7	2.7
8	3.2
9	1.6
10	0.2
11	0
12	3.3
13	0
14	3.2
15	3.2

CN102

Pin No.	Voltage
1	0
2	1.2
3	0
4	3.3
5	2.5
6	1.9
7	0
8	0
9	3.2
10	0
11	0
12	0
13	0
14	3.3
15	2.4
16	2.4
17	0
18	1.0
19	0
20	0

# Digital 2/3 Schematic Diagram

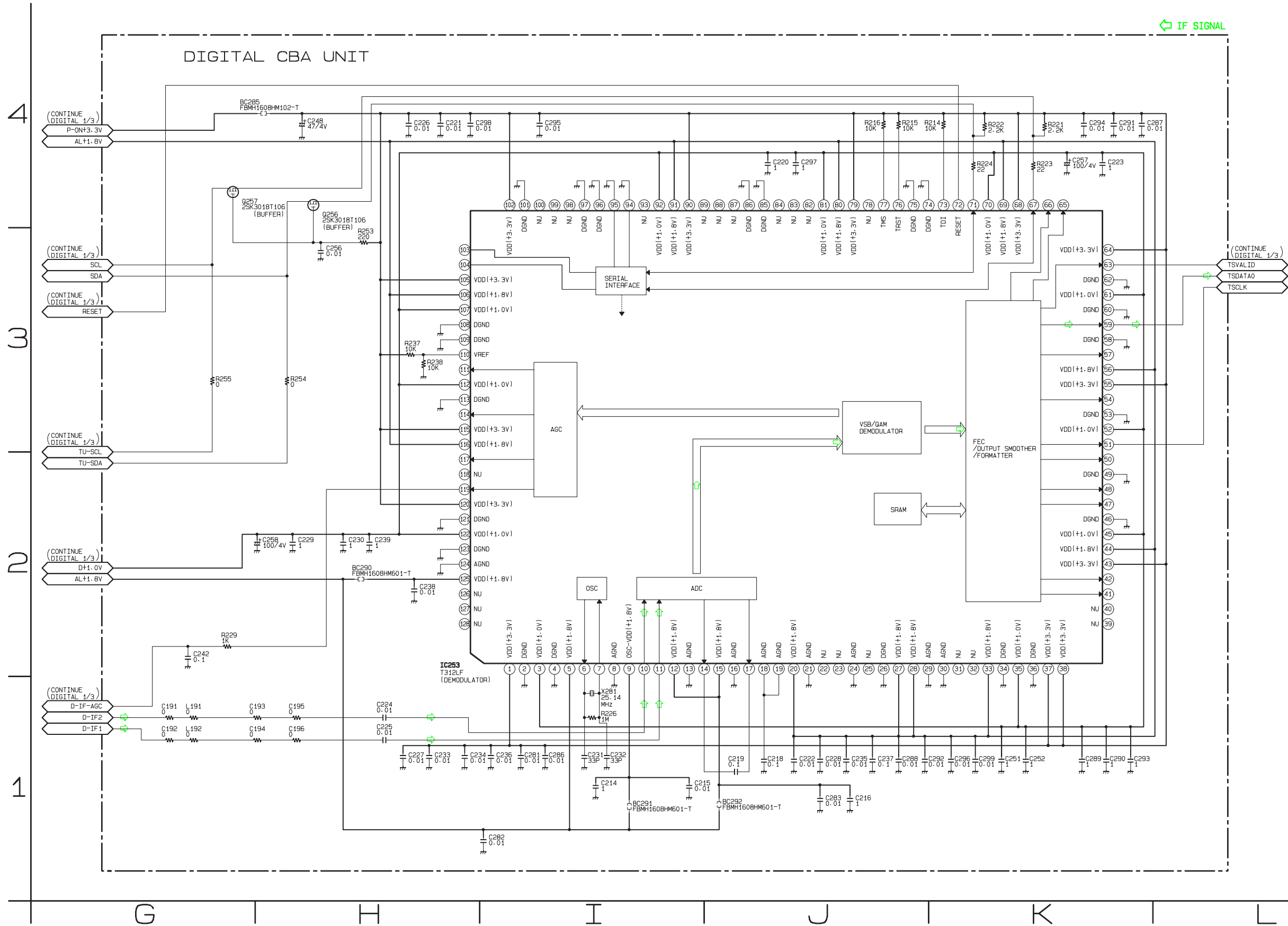



# Digital 3/3 Schematic Diagram

**\*1 NOTE:**

1. The order of pins shown in this diagram is different from that of actual IC101.
2. IC101 is divided into two and shown as IC101 (1/2) ~ IC101 (2/2) in this Digital Schematic Diagram Section.

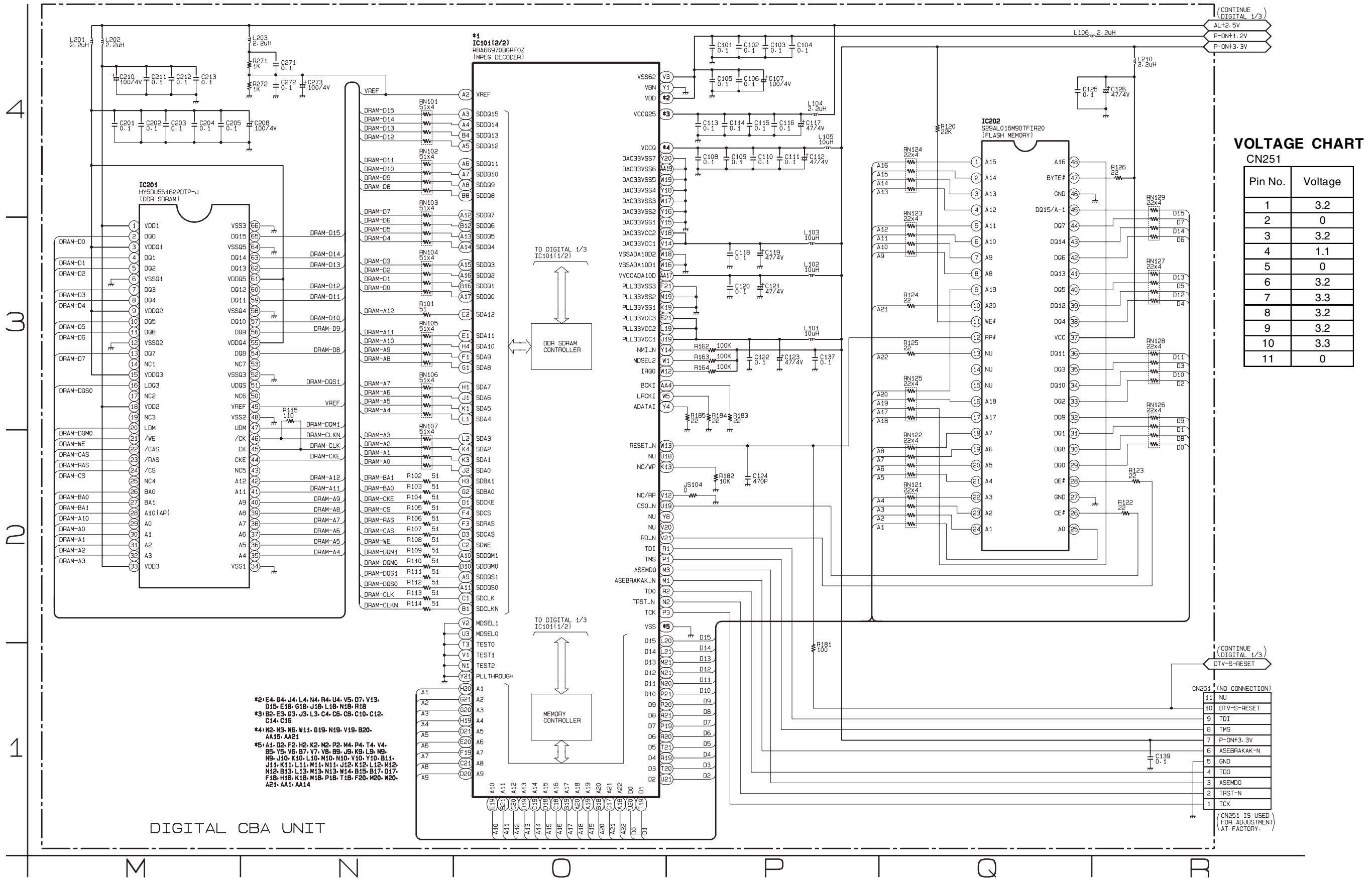

## VOLTAGE CHART

CN251

Pin No.	Voltage
1	3.2
2	0
3	3.2
4	1.1
5	0
6	3.2
7	3.3
8	3.2
9	3.2
10	3.3
11	0

- \*2: E4, G4, J4, L4, N4, R4, U4, V5, D7, V13, D15, E18, G18, J18, L18, N18, R18
- \*3: B2, E3, G3, J3, L3, C4, C5, C8, C10, C12, C14, C16
- \*4: H2, N3, N6, W11, G19, N19, V19, B20, AA15, AA21
- \*5: A1, D2, F2, H2, K2, M2, P2, M4, P4, T4, V4, B5, Y5, V6, B7, V7, V8, B9, J9, K9, L9, M9, N9, J10, K10, L10, M10, N10, V10, Y10, B11, J11, K11, L11, M11, N11, J12, K12, L12, M12, N12, B13, L13, M13, N13, W14, B15, B17, D17, F18, H18, K18, N18, P18, T18, F20, M20, W20, A21, AA1, AA14

CONTINUE DIGITAL 1/3

DTV-S-RESET

Pin No.	Signal
11	NU
10	DTV-S-RESET
9	TDI
8	TMS
7	P-ON+3.3V
6	ASEBRAKAK-N
5	GND
4	TDO
3	ASEMDO
2	TRST-N
1	TCK

(CN251 IS USED FOR ADJUSTMENT AT FACTORY.)

# Main CBA Top View

## CAUTION !

Fixed voltage (or Auto voltage selectable) power supply circuit is used in this unit.  
 If Main Fuse (F601) is blown, check to see that all components in the power supply circuit are not defective before you connect the AC plug to the AC power supply.  
 Otherwise it may cause some components in the power supply circuit to fail.

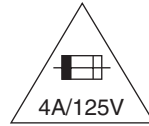

**CAUTION ! :** For continued protection against risk of fire,  
 replace only with same type 4 A, 125V fuse.

**ATTENTION :** Utiliser un fusible de rechange de même type de 4A, 125V.

## NOTE:

The voltage for parts in hot circuit is measured using hot GND as a common terminal.

Because a hot chassis ground is present in the power supply circuit, an isolation transformer must be used.  
 Also, in order to have the ability to increase the input slowly, when troubleshooting this type power supply circuit, a variable isolation transformer is required.

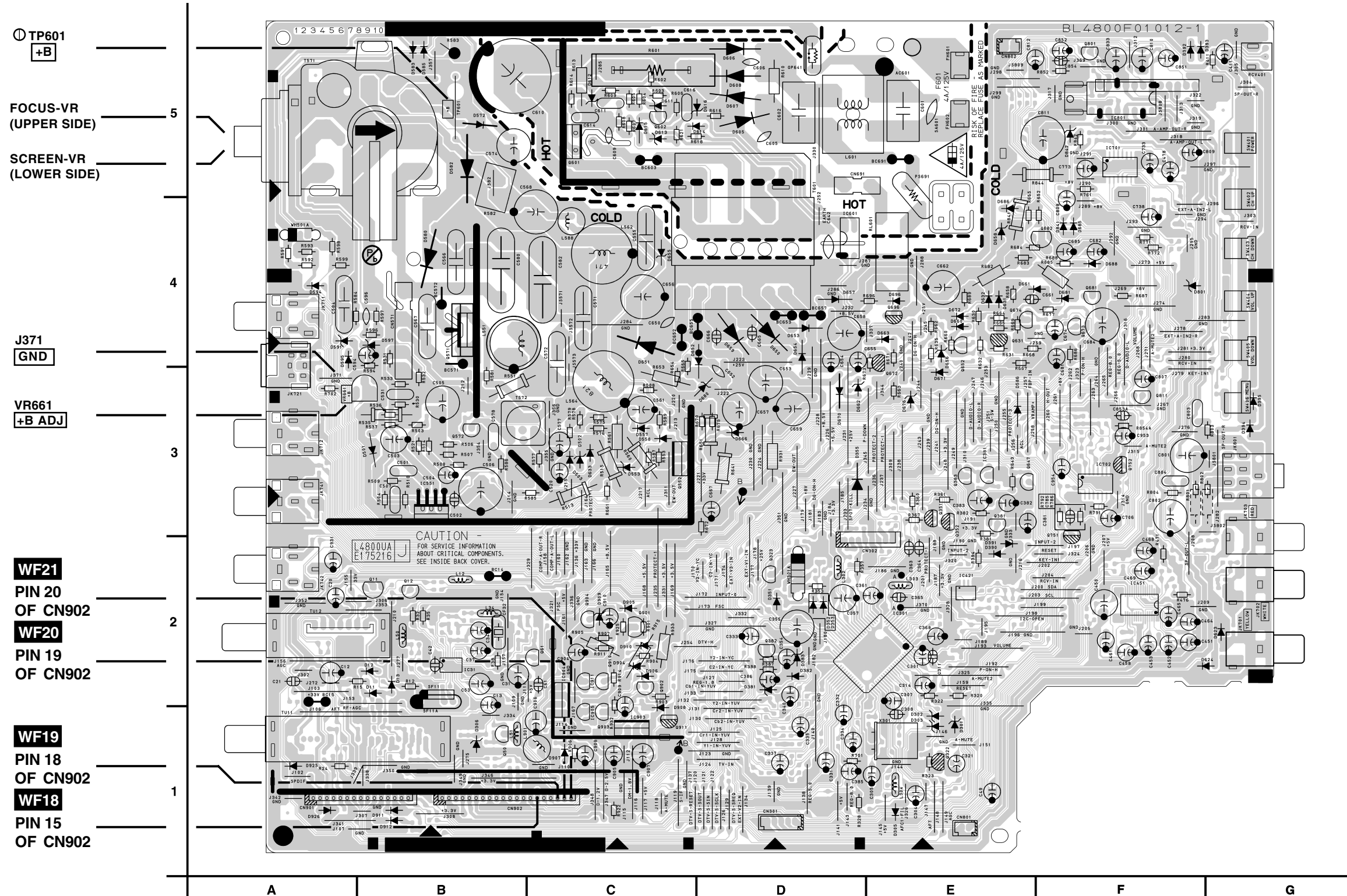

# Main CBA Bottom View

## CAUTION !

Fixed voltage (or Auto voltage selectable) power supply circuit is used in this unit. If Main Fuse (F601) is blown, check to see that all components in the power supply circuit are not defective before you connect the AC plug to the AC power supply. Otherwise it may cause some components in the power supply circuit to fail.

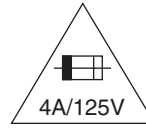

**CAUTION ! :** For continued protection against risk of fire, replace only with same type 4 A, 125V fuse.  
**ATTENTION :** Utiliser un fusible de rechange de même type de 4A, 125V.

## NOTE:

The voltage for parts in hot circuit is measured using hot GND as a common terminal.

Because a hot chassis ground is present in the power supply circuit, an isolation transformer must be used. Also, in order to have the ability to increase the input slowly, when troubleshooting this type power supply circuit, a variable isolation transformer is required.

**WF11**  
PIN 3  
OF IC801

**WF12**  
PIN 14  
OF IC801

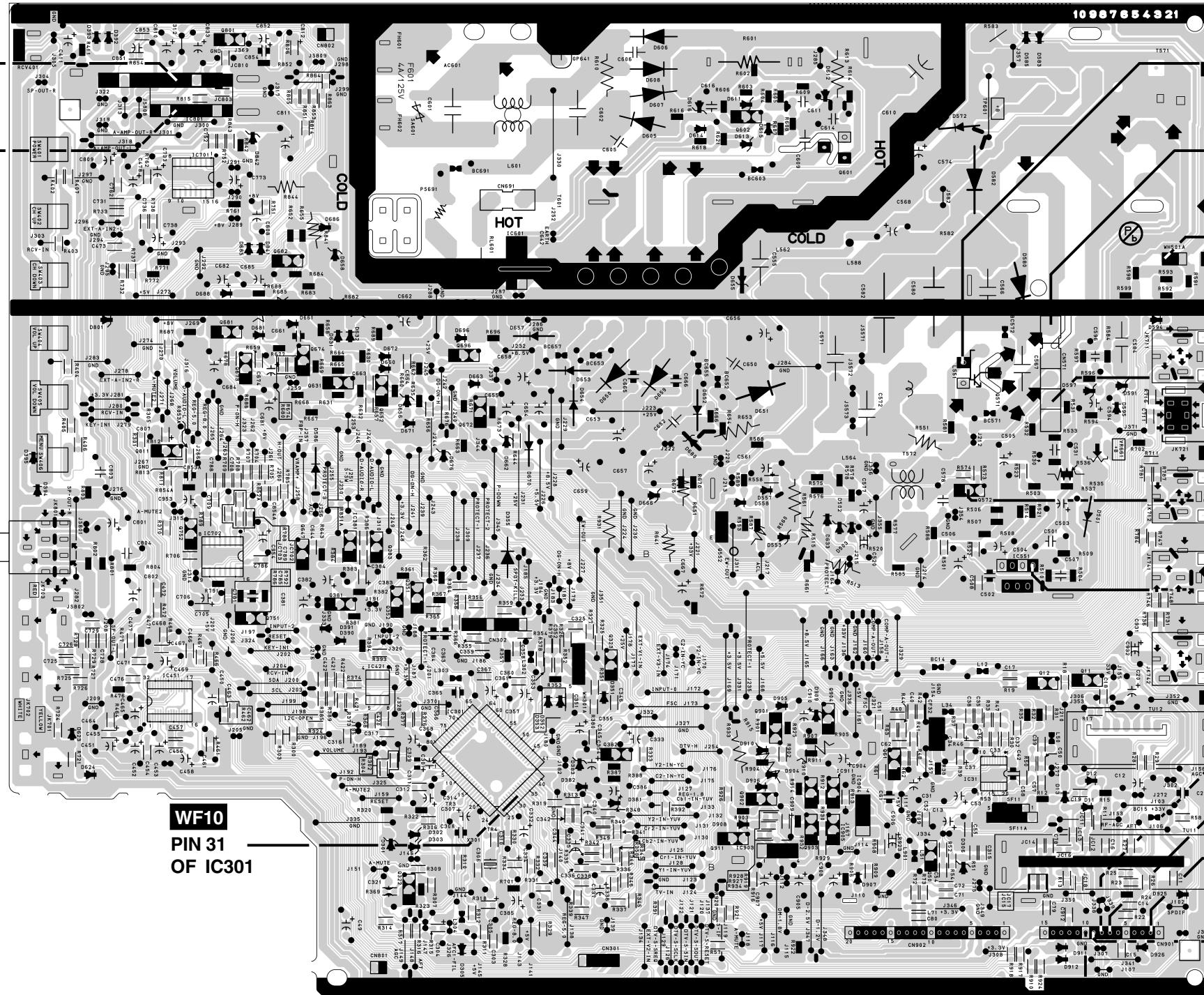

**WF10**  
PIN 31  
OF IC301

**WF7**  
Q571  
Base

**WF4**  
PIN 1  
OF CN571

**WF6**  
PIN 3  
OF WH501A

**WF5**  
PIN 4  
OF CN571

**WF8**  
Q572  
Collector

**WF9**  
PIN 7  
OF IC551

**WF15**  
PIN 8  
OF CN901

**WF14**  
PIN 7  
OF CN901

**WF13**  
PIN 2  
OF CN901

**WF16**  
PIN 9  
OF CN901

**WF17**  
PIN 10  
OF CN901

G F E D C B A



# WAVEFORMS

**WF1 ~ WF21** = Waveforms to be observed at  
Waveform check points.  
(Shown in Schematic Diagram.)

**Input:** Color Bar Signal (with 1kHz Audio Signal)  
**INITIAL POSITION:** Unplug unit from AC outlet for at least 5 minutes.  
reconnect to AC outlet and then turn power on.

(Brightness---Center Color---Center Tint --- Center Contrast---Approx 70%)

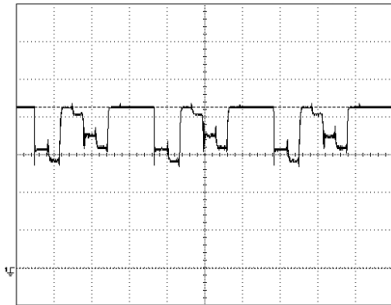

**WF1** 1DIV: 50V 20µs  
Q1512 Collector

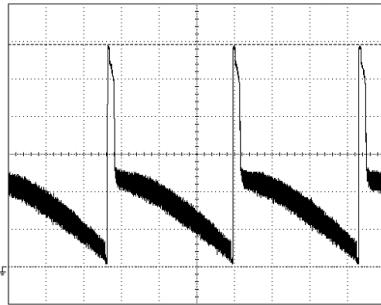

**WF5** 1DIV: 10V 5ms  
Pin 4 of CN571

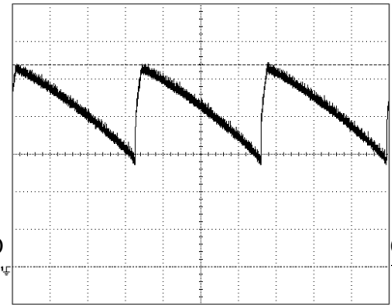

**WF9** 1DIV: 1V 5ms  
Pin 7 of IC551

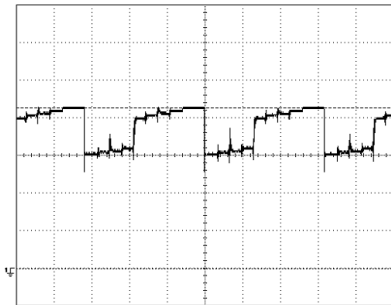

**WF2** 1DIV: 50V 20µs  
Q1522 Collector

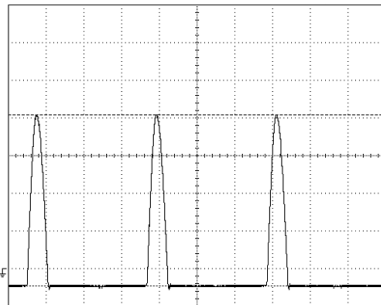

**WF6** 1DIV: 5V 20µs  
Pin 3 of WH501A

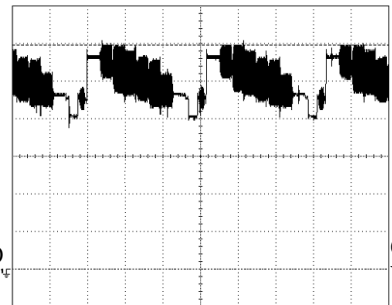

**WF10** 1DIV: 500mV 20µs  
Pin 31 of IC301

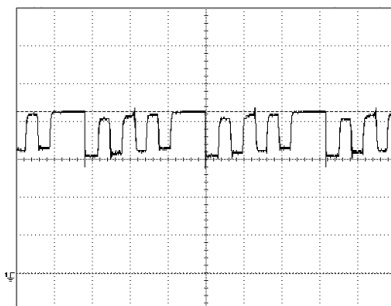

**WF3** 1DIV: 50V 20µs  
Q1532 Collector

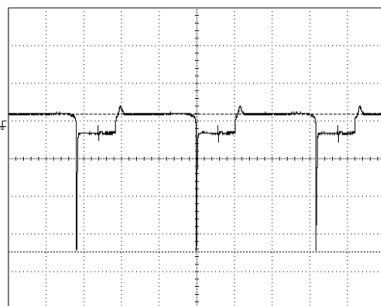

**WF7** 1DIV: 5V 20µs  
Q571 Base

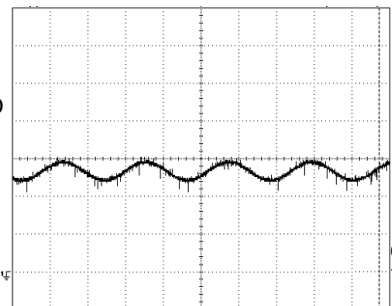

**WF11** 1DIV: 500mV 500µs  
Pin 3 of IC801

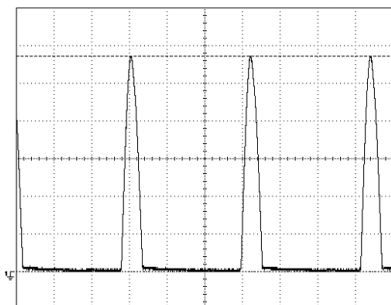

**WF4** 1DIV: 200V 20µs  
Pin 1 of CN571

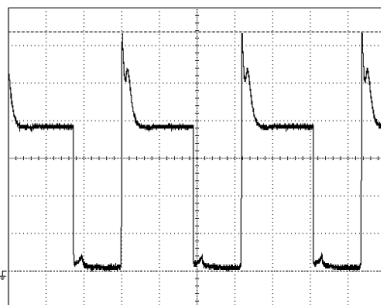

**WF8** 1DIV: 10V 20µs  
Q572 Collector

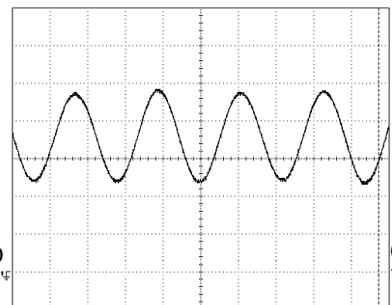

**WF12** 1DIV: 2V 500µs  
Pin 14 of IC801

**WF1 ~ WF21** = Waveforms to be observed at  
Waveform check points.  
(Shown in Schematic Diagram.)

**Input:** Color Bar Signal (with 1kHz Audio Signal)

**INITIAL POSITION:** Unplug unit from AC outlet for at least 5 minutes.  
reconnect to AC outlet and then turn power on.

**(Brightness---Center Color---Center Tint --- Center Contrast---Approx 70%)**

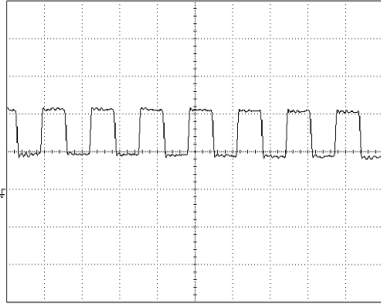

**WF13** 1DIV: 1V 500ns  
Pin 2 of CN901

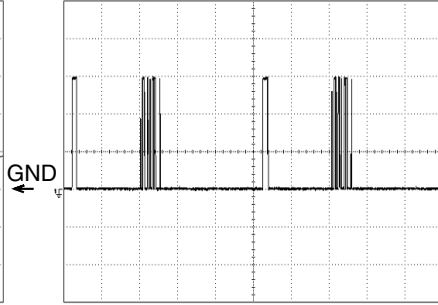

**WF17** 1DIV: 1V 20ms  
Pin 10 of CN901

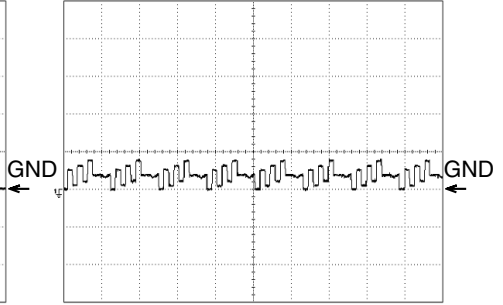

**WF21** 1DIV: 1V 50μs  
Pin 20 of CN902

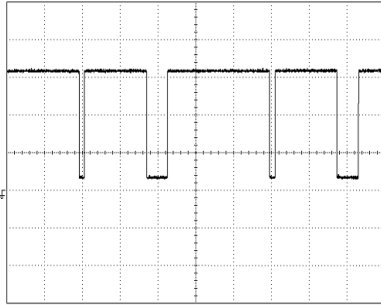

**WF14** 1DIV: 1V 20ms  
Pin 7 of CN901

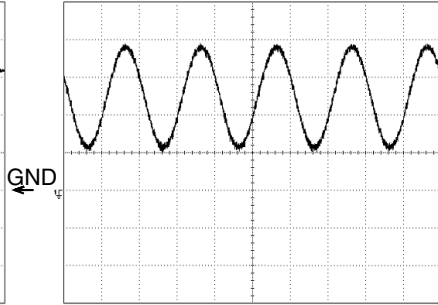

**WF18** 1DIV: 1V 500μs  
Pin 15 of CN902

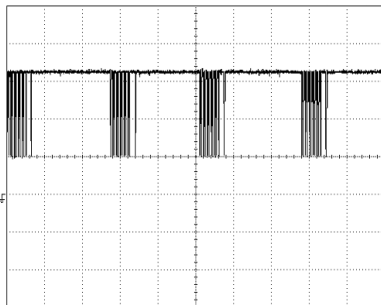

**WF15** 1DIV: 1V 20ms  
Pin 8 of CN901

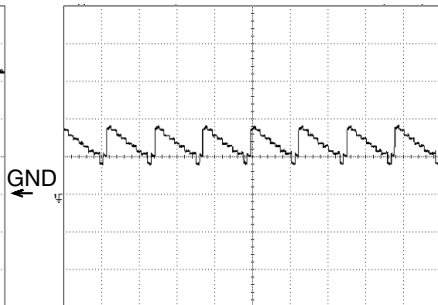

**WF19** 1DIV: 1V 50μs  
Pin 18 of CN902

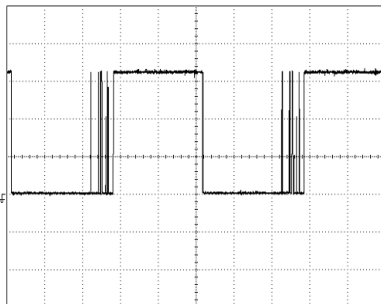

**WF16** 1DIV: 1V 20ms  
Pin 9 of CN901

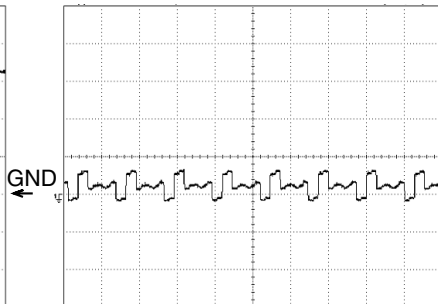

**WF20** 1DIV: 1V 50μs  
Pin 19 of CN902

# WIRING DIAGRAM

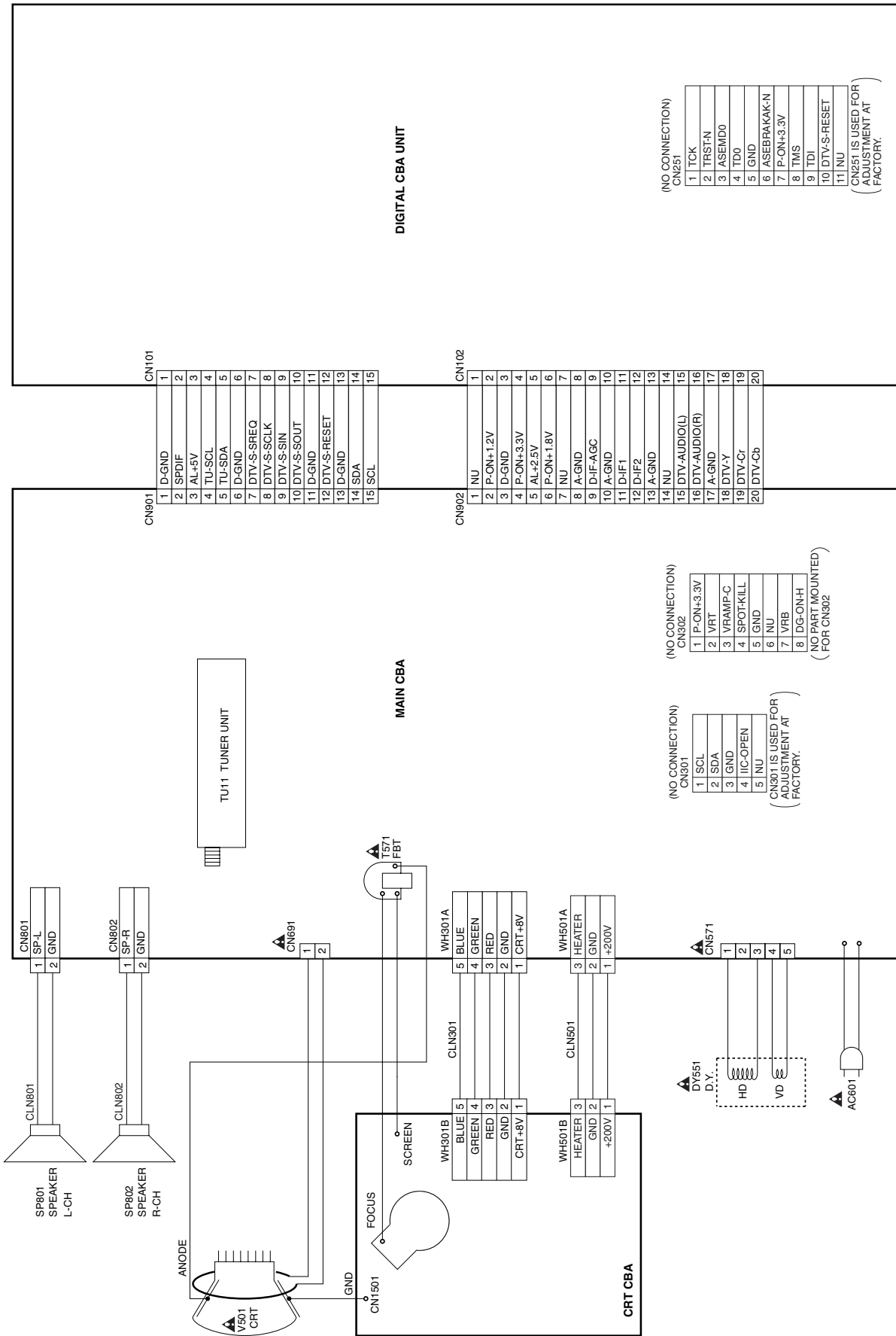

# IC PIN FUNCTION DESCRIPTIONS

## IC301 (TV Micro Controller)

Pin No.	Signal Name	Function
1	RCV-IN	Remote Control Signal Input
2	VOLUME	Volume Control Signal Output
3	DTV-H	DTV On Signal at High
4	P-ON-H	Power On Signal at High
5	RESET	Reset
6	NU	Not Used
7	ACL	Automatic Contrast Limiter
8	PROTECT-3	Power Supply Protection 3
9	AUDIO-MUTE2	Audio Mute 2 Signal Output
10	AUDIO-MUTE1	Audio Mute 1 Signal Output
11	NU	Not Used
12	AFT-IN	AFT Voltage Input
13	DEF-VCC	DEF VCC(+8V)
14	VRAMP+	Vertical Ramp+
15	NU	Not Used
16	AFC1-FIL	Horizontal AFC1 Filter
17	DEF-VCC	DEF VCC(+5.0V)
18	HOUT	Horizontal Pulse Output
19	FBP-IN	Flyback Pulse Input
20	GND	GND
21	C-APC	Chrominance APC
22	XTAL	Crystal Oscillation(3.58MHz)
23	GND	Chrominance GND
24	NU	Not Used
25	EW-OUT	EW-OUT
26	NU	Not Used
27	NU	Not Used
28	+8V-CTRL	+8V Regulator Control Signal Output
29	CVBS2-IN	Composite Video Signal 2 Input
30	VCC(+5V)	Chrominance VCC(+5.0V)
31	CVBS1-IN	Composite Video Signal 1 Input
32	+5V-CTRL	+5V Regulator Control Signal Output
33	Cr1-IN[YUV]	Component Video Cr Signal Input
34	Cb1-IN[YUV]	Component Video Cb Signal Input
35	Y1-IN[YUV]	Component Video Y Signal Input

Pin No.	Signal Name	Function
36	+1.8V-CTRL	+1.8V Regulator Control Signal Output
37	C-IN[YC]	Chrominance Signal Input
38	Y-IN[YC]	Luminance Signal Input
39	NU	Not Used
40	Cb2-IN[YUV]	DTV Cb Signal Input
41	Cr2-IN[YUV]	DTV Cr Signal Input
42	Y2-IN[YUV]	DTV Y Signal Input
43	NU	Not Used
44	VCC(+9V)	VREG VCC
45	CVBS3-IN	Composite Video Signal 3 Input
46	NU	Not Used
47	FSC-OUT	Clock Output
48	VCC(+8V)	HI VCC(+8V)
49	R-OUT	Red Signal Output
50	G-OUT	Green Signal Output
51	B-OUT	Blue Signal Output
52	ANALOG-VCC	Analog VCC(3.3V)
53	VRT	Vref Top
54	NU	Not Used
55	VRB	Vref Bottom
56	RAMPFIL	Ramp Filter
57	GND	Analog GND
58	VRAMP-C	Vertical Ramp Capacitor
59	GND	Sub GND
60	PROTECT-2	Power Supply Protection 2
61	NU	Not Used
62	INPUT1	Input Select 1 Signal Output
63	INPUT0	Input Select 0 Signal Output
64	DTV-S-RESET	DTV Reset
65	NU	Not Used
66	VDD(+3.3V)	+3.3V DIGI VDD
67	DTV-S-SREQ	DTV Serial Request
68	DTV-S-SCLK	DTV Serial Clock
69	GND	GND
70	DTV-S-SIN	DTV Serial Data In
71	VDD(+1.8V)	+1.8V DIGI VDD
72	DTV-S-SOUT	DTV Serial Data Out
73	KEY-IN1	Key Input 1
74	PROTECT-1	Power Supply Protection 1
75	DG-ON-H	Degaussing Coil Control Signal



<b>Pin No.</b>	<b>Signal Name</b>	<b>Function</b>
76	SPOT-KILL	Counter Measure for Spot
77	SCL	Serial Clock
78	I2C-OPEN	Chip Select
79	SDA	Serial Data
80	S-SW	Detecting S-VIDEO Jack Connection

# EXPLODED VIEWS

## Cabinet

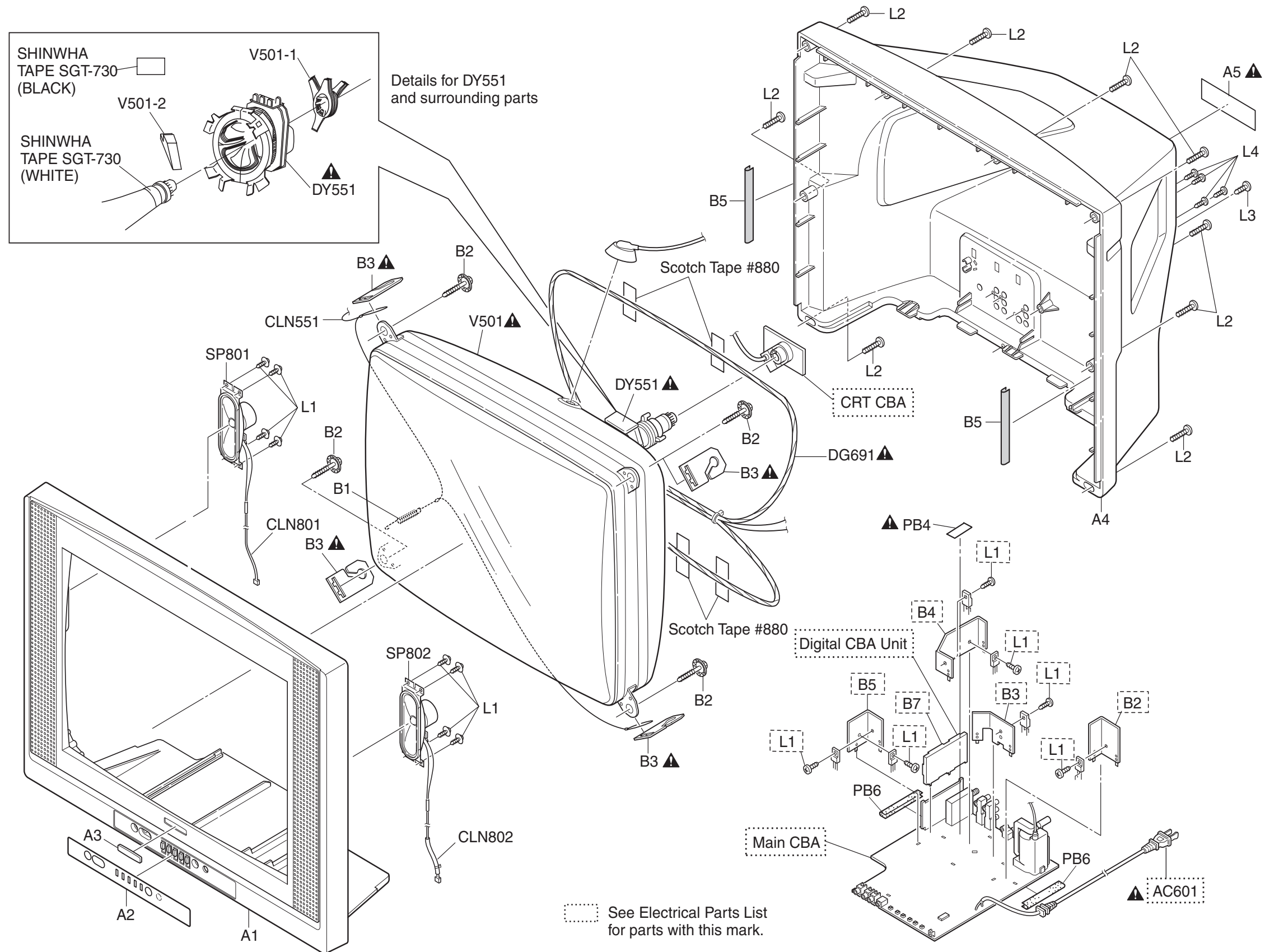

# Packing

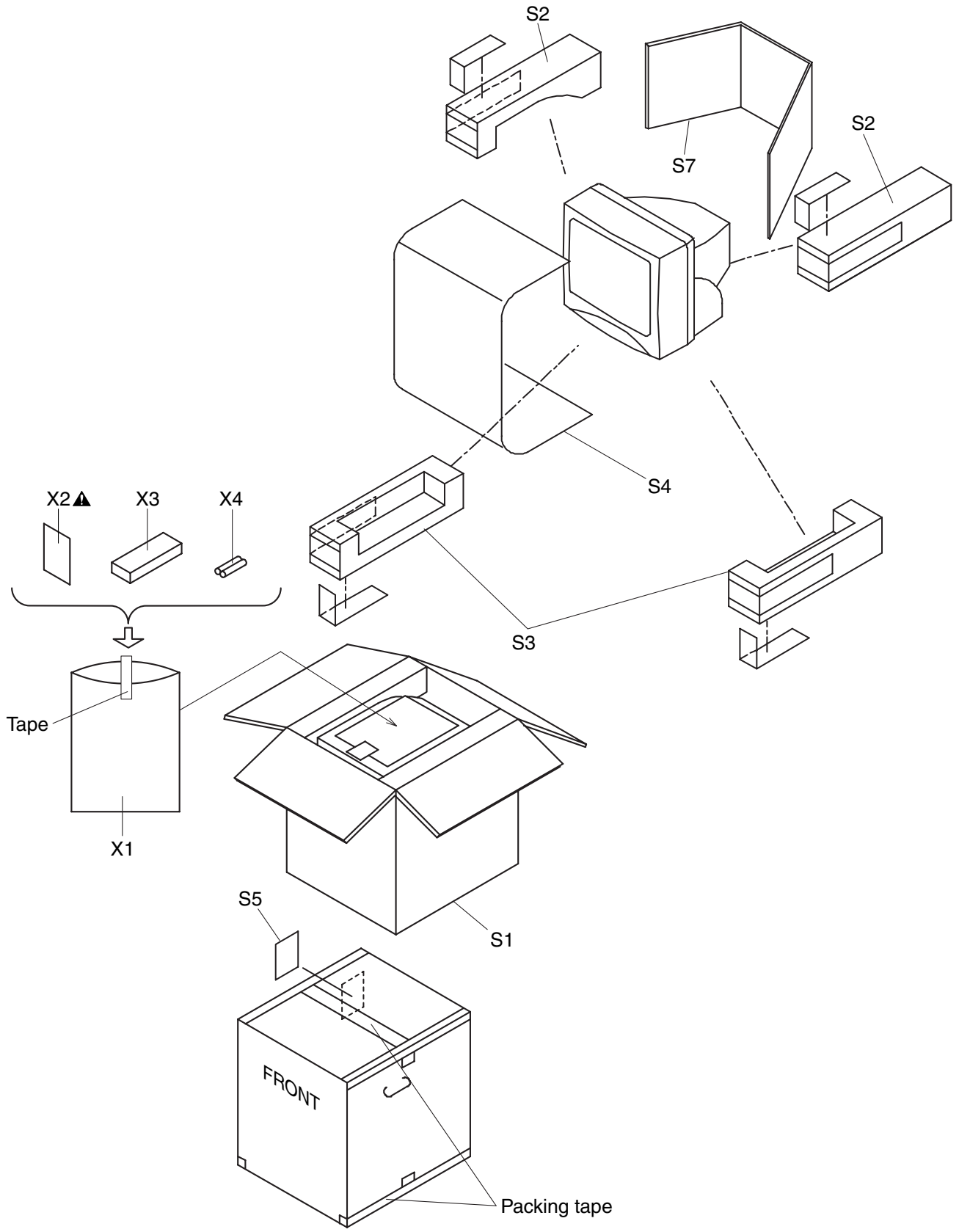

# MECHANICAL PARTS LIST

**PRODUCT SAFETY NOTE:** Products marked with a **▲** have special characteristics important to safety. Before replacing any of these components, read carefully the product safety notice in this service manual. Don't degrade the safety of the product through improper servicing.

**NOTE:** Parts that are not assigned part numbers (-----) are not available.

Ref. No.	Description	Part No.
A1	FRONT CABINET L4705UF	1EM021350
A2	CONTROL PLATE L4804UE	1EM321329
A3	BRAND PLATE L6654UE	0EM408562
A4	REAR CABINET L4705UF	1EM021292
A5▲	RATING LABEL L4705UF	-----
B1	SPRING TENSION B0080B0 EM40808	26WH006
B2	SCREW M7 CRT(D22) T7205UF	0EM406573A
B3▲	HOLDER DEGAUSS L1200UA	0EM405869
B5	CLOTH L9800UA 95X15XT 0.0.5	0EM405041
CLN551	CRT GND WIRE	WX1L1200-007
CLN801	WIRE ASSEMBLY WX1L6615-002	WX1L6615-002
CLN802	WIRE ASSEMBLY WX1L2805-003	WX1L2805-003
DG691▲	DEGAUSSING COIL (PB FREE) VRK0955-065-070	LLBH00Z0V005
L1	SCREW ASSEMBLED M3X12	0EM406746A
L2	SCREW P-TIGHT 4X18 BIND HEAD +	GBJP4180
L3	SCREW TAPPING M4X14	DBT14140
L4	SCREW P-TIGHT 3X10 BIND HEAD+	GBHP3100
PB4▲	CHASSIS NO. LABEL L1627V2	-----
PB6	CLOTH(65) L7735TR 65X10X0.5T	0EM402149
SP801	SPEAKER S0516F01	DSD0813XQ001
SP802	SPEAKER S0516F01	DSD0813XQ001
<b>PACKING</b>		
S1	CARTON L4705UF	1EM422803
S2	STYROFOAM TOP ASSEMBLY L4705UF	1EM423080
S3	STYROFOAM BOTTOM ASSEMBLY L4705UF	1EM423081
S4	SHEET SET PCEC 003502019816	0EM403887
S5	SERIAL NO. LABEL L4705UF	-----
S7	HOLD PAD L4802UC	1EM423077
<b>ACCESSORIES</b>		
X1	BAG POLYETHYLENE 235X365XT0.03	0EM408420A
X2▲	OWNERS MANUAL L4705UF	1EMN21390
X3	REMOTE CONTROL NE601UE	NE601UE
X4	DRY BATTERY R6P/2S	XB0M451T0001
<b>Note:</b> 1. V501 (CRT) HAS COUPLE OF SUBSTITUTIONAL PARTS AND EACH PARTS ALSO HAS MATCHING COMBINATION WITH L551. PLEASE SEE TABLE 1 FOR DETAILS OF MATCHING COMBINATION. 2. L551 (DEFLECTION YOKE) HAS MATCHING COMBINATION WITH V501. PLEASE SEE TABLE 1 FOR DETAILS OF MATCHING COMBINATION.		
<b>CRT TYPE A</b>		
DY551▲	DEFLECTION YOKE ODY-C29029	LLBY00ZQS006
V501▲	CRT A68KTB359X(B)	TCRT190QS024
V501-1	PCM JH88DTA	XM04000BV010
V501-2	WEDGE FT-00110W	XV10000T4001
<b>CRT TYPE B</b>		
DY551▲	DEFLECTION YOKE CDY-F2927H	LLBY00ZQS014
V501▲	CRT A68QBT892X	TCRT190SM028
V501-1	PCM JH88DTA	XM04000BV010
V501-2	WEDGE FT-00110W	XV10000T4001

Ref. No.	Description	Part No.
<b>CRT TYPE C</b>		
DY551▲	DEFLECTION YOKE 6150Z-1046A	LLBY00ZGS008
V501▲	CRT A68QBC230X	TCRT190GS043
V501-1	PCM JH88DTA	XM04000BV010
V501-2	WEDGE FT-00110W	XV10000T4001

**Table 1 (V501 and DY551 Combination)**

**Note 1:** Purity and Convergence Adjustments must be performed following CRT replacement. Refer to Electrical Adjustment Instructions.

**Note 2:** Please confirm CRT Type No. on the CRT Warning Label which is located on the CRT. Then See the Table 1 for V501 and DY551 combination chart. Please refer this CRT, Deflection Yoke combination chart for parts order.

V501: CRT Type No.	V501: CRT Part No.	DY551: Deflection Yoke Part No.
A68KTB359X(B)	TCRT190QS024	LLBY00ZQS006
A68QBT892X	TCRT190SM028	LLBY00ZQS014
A68QBC230X	TCRT190GS043	LLBY00ZGS008

## CRT Warning Label Location

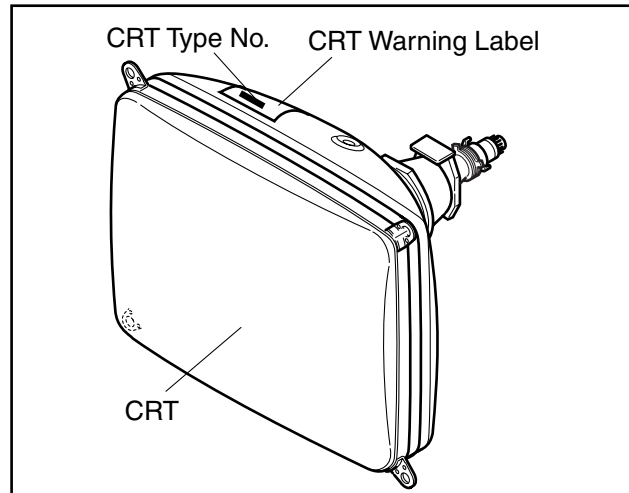

# ELECTRICAL PARTS LIST

**PRODUCT SAFETY NOTE:** Products marked with a **▲** have special characteristics important to safety. Before replacing any of these components, read carefully the product safety notice in this service manual. Don't degrade the safety of the product through improper servicing.

**NOTES:**

- Parts that are not assigned part numbers (-----) are not available.
- Tolerance of Capacitors and Resistors are noted with the following symbols.

C.....±0.25%    D.....±0.5%    F.....±1%  
 G.....±2%    J.....±5%    K.....±10%  
 M.....±20%    N.....±30%    Z.....+80/-20%

## DIGITAL CBA UNIT

Ref. No.	Description	Part No.
	DIGITAL CBA UNIT	1ESA12337

## MMA CBA

Ref. No.	Description	Part No.
	MMA CBA Consists of the following:	1ESA12341
	MAIN CBA CRT CBA	----- -----

## MAIN CBA

Ref. No.	Description	Part No.
	MAIN CBA Consists of the following:	-----
<b>CAPACITORS</b>		
C12	ELECTROLYTIC CAP. 100µF/ 10V M	CE1AMASDL101
C19	CHIP RES.(1608) 1/10W 0 Ω	RRXAJR5Z0000
C21	CERAMIC CAP.(AX) B K 1000pF/50V	CCA1JKT0B102
C31	ELECTROLYTIC CAP. 100µF/ 10V M	CE1AMASDL101
C34	ELECTROLYTIC CAP. 0.47µF/ 50V M	CE1JMASDLR47
C35	CHIP CERAMIC CAP.(1608) CH J 47pF/50V	CHD1JJ3CH470
C36	CHIP CERAMIC CAP.(1608) B K 1000pF/50V	CHD1JK30B102
C37	ELECTROLYTIC CAP. 1µF/ 50V M	CE1JMASDL1R0
C38	CHIP CERAMIC CAP.(1608) CH J 47pF/50V	CHD1JJ3CH470
C39	CHIP CERAMIC CAP. CH D 5pF/50V	CHD1JD3CH5R0
C42	CERAMIC CAP.(AX) CH K 2.7pF/50V	CCA1JKTCH2R7
C49	ELECTROLYTIC CAP. 4.7µF/ 50V M	CE1JMASDL4R7
C50	CHIP CERAMIC CAP. CH C 3pF/50V	CHD1JC3CH3R0
C51	CHIP CERAMIC CAP.(1608) B K 1000pF/50V	CHD1JK30B102
C52	CHIP CERAMIC CAP. F Z 0.01µF/ 50V	CHD1JZ30F103
C53	ELECTROLYTIC CAP. 100µF/ 10V M	CE1AMASDL101
C54	CHIP CERAMIC CAP.(1608) B K 1000pF/50V	CHD1JK30B102
C55	CHIP CERAMIC CAP. F Z 0.01µF/ 50V	CHD1JZ30F103
C57	CHIP CERAMIC CAP.(1608) B K 0.047µF/ 50V	CHD1JK30B473
C58	CHIP CERAMIC CAP.(1608) B K 0.033µF/ 50V	CHD1JK30B333
C61	CERAMIC CAP.(AX) F Z 0.01µF/ 25V	CCA1EZTFZ103
C62	CHIP CERAMIC CAP.(1608) B K 0.01µF/ 50V	CHD1JK30B103
C71	CHIP RES.(1608) 1/10W 0 Ω	RRXAJR5Z0000

Ref. No.	Description	Part No.
C72	CHIP RES.(1608) 1/10W 0 Ω	RRXAJR5Z0000
C78	CHIP CERAMIC CAP.(1608) B K 1000pF/50V	CHD1JK30B102
C79	CHIP CERAMIC CAP. F Z 0.01µF/ 50V	CHD1JZ30F103
C301	ELECTROLYTIC CAP. 10µF/ 50V M	CE1JMASDL100
C303	CHIP CERAMIC CAP.(1608) B K 0.01µF/ 50V	CHD1JK30B103
C304	ELECTROLYTIC CAP. 1µF/ 50V M	CE1JMASDL1R0
C305	ELECTROLYTIC CAP. 0.47µF/ 50V M	CE1JMASDLR47
C306	CHIP CERAMIC CAP.(1608) B K 0.015µF/ 50V	CHD1JK30B153
C307	ELECTROLYTIC CAP. 47µF/ 16V M	CE1CMASDL470
C308	CERAMIC CAP.(AX) F 0.1µF/ 50V	CCK1JZT0F104
C309	CHIP CERAMIC CAP. F Z 0.01µF/ 50V	CHD1JZ30F103
C310	CHIP CERAMIC CAP. CH J 120pF/50V	CHD1JJ3CH121
C311	CERAMIC CAP.(AX) F Z 0.01µF/ 25V	CCA1EZTFZ103
C314	ELECTROLYTIC CAP. 0.1µF/ 50V M	CE1JMASDL0R1
C316	CHIP CERAMIC CAP. F Z 0.01µF/ 50V	CHD1JZ30F103
C317	CHIP CERAMIC CAP. F Z 1000pF/50V	CHD1JZ30F102
C321	ELECTROLYTIC CAP. 4.7µF/ 50V M NP	CP1JMASNC4R7
C331	ELECTROLYTIC CAP. 1µF/ 50V M	CE1JMASDL1R0
C332	ELECTROLYTIC CAP. 1µF/ 50V M	CE1JMASDL1R0
C333	ELECTROLYTIC CAP. 1µF/ 50V M	CE1JMASDL1R0
C335	ELECTROLYTIC CAP. 1µF/ 50V M	CE1JMASDL1R0
C336	CHIP CERAMIC CAP.(1608) B K 1000pF/50V	CHD1JK30B102
C337	ELECTROLYTIC CAP. 1µF/ 50V M	CE1JMASDL1R0
C338	CHIP CERAMIC CAP.(1608) F Z 0.1µF/ 25V	CHD1EZ30F104
C339	CHIP CERAMIC CAP.(1608) F Z 0.1µF/ 25V	CHD1EZ30F104
C340	ELECTROLYTIC CAP. 1µF/ 50V M	CE1JMASDL1R0
C341	CHIP CERAMIC CAP.(1608) F Z 0.1µF/ 25V	CHD1EZ30F104
C342	CHIP CERAMIC CAP.(1608) F Z 0.1µF/ 25V	CHD1EZ30F104
C345	CHIP CERAMIC CAP. F Z 0.01µF/ 50V	CHD1JZ30F103
C346	CHIP CERAMIC CAP. F Z 0.01µF/ 50V	CHD1JZ30F103
C354	ELECTROLYTIC CAP. 10µF/ 50V M	CE1JMASDL100
C355	ELECTROLYTIC CAP. 470µF/ 10V M	CE1AMASDL471
C357	ELECTROLYTIC CAP. 470µF/ 6.3V M	CE0KMASDL471
C358	CHIP CERAMIC CAP.(1608) B K 0.1µF/ 50V	CHD1JK30B104
C359	CHIP CERAMIC CAP.(1608) B K 0.1µF/ 50V	CHD1JK30B104
C360	CHIP CERAMIC CAP.(1608) B K 0.033µF/ 50V	CHD1JK30B333
C361	ELECTROLYTIC CAP. 10µF/ 50V M	CE1JMASDL100
C363	CERAMIC CAP.(AX) F Z 0.01µF/ 25V	CCA1EZTFZ103
C364	CERAMIC CAP.(AX) F Z 0.01µF/ 25V	CCA1EZTFZ103
C365	CERAMIC CAP.(AX) F Z 0.01µF/ 25V	CCA1EZTFZ103
C366	CHIP CERAMIC CAP. F Z 1µF/ 10V	CHD1AZ30F105
C368	ELECTROLYTIC CAP. 100µF/ 6.3V M	CE0KMASDL101
C381	ELECTROLYTIC CAP. 100µF/ 10V M	CE1AMASDL101
C382	ELECTROLYTIC CAP. 47µF/ 16V M	CE1CMASDL470
C383	ELECTROLYTIC CAP. 470µF/ 6.3V M	CE0KMASDL471
C384	CHIP CERAMIC CAP. F Z 0.01µF/ 50V	CHD1JZ30F103
C385	ELECTROLYTIC CAP. 100µF/ 10V M	CE1AMASDL101
C386	ELECTROLYTIC CAP. 10µF/ 50V M	CE1JMASDL100
C411	ELECTROLYTIC CAP. 10µF/ 50V M	CE1JMASDL100
C420	CHIP CERAMIC CAP.(1608) F Z 0.1µF/ 50V	CHD1JZ30F104
C450	ELECTROLYTIC CAP. 100µF/ 10V M	CE1AMASDL101
C451	ELECTROLYTIC CAP. 10µF/ 50V M	CE1JMASDL100
C452	ELECTROLYTIC CAP. 3.3µF/ 50V M	CE1JMASDL3R3
C453	ELECTROLYTIC CAP. 3.3µF/ 50V M	CE1JMASDL3R3
C454	CHIP CERAMIC CAP.(1608) B K 0.1µF/ 50V	CHD1JK30B104
C455	CHIP CERAMIC CAP.(1608) B K 0.022µF/ 50V	CHD1JK30B223
C456	CHIP CERAMIC CAP.(1608) F Z 0.1µF/ 50V	CHD1JZ30F104
C457	CHIP CERAMIC CAP.(1608) B K 0.033µF/ 50V	CHD1JK30B333
C458	ELECTROLYTIC CAP. 2.2µF/ 50V M	CE1JMASDL2R2
C461	ELECTROLYTIC CAP. 0.33µF/ 50V M	CE1JMASDLR33

Ref. No.	Description	Part No.
C462	CHIP CERAMIC CAP.(1608) B K 0.1μF/50V	CHD1JK30B104
C463	CHIP CERAMIC CAP.(1608) B K 0.1μF/50V	CHD1JK30B104
C464	ELECTROLYTIC CAP. 4.7μF/50V M	CE1JMASDL4R7
C465	ELECTROLYTIC CAP. 2.2μF/50V M	CE1JMASDL2R2
C466	CHIP CERAMIC CAP. CH J 150pF/50V	CHD1JJ3CH151
C467	CHIP CERAMIC CAP. CH J 150pF/50V	CHD1JJ3CH151
C468	ELECTROLYTIC CAP. 2.2μF/50V M	CE1JMASDL2R2
C469	ELECTROLYTIC CAP. 2.2μF/50V M	CE1JMASDL2R2
C471	CHIP CERAMIC CAP. F Z 1μF/10V	CHD1AZ30F105
C472	CHIP CERAMIC CAP.(1608) B K 4700pF/50V	CHD1JK30B472
C473	CHIP CERAMIC CAP. F Z 1μF/10V	CHD1AZ30F105
C476	CHIP CERAMIC CAP. F Z 1μF/10V	CHD1AZ30F105
C477	CHIP CERAMIC CAP.(1608) B K 4700pF/50V	CHD1JK30B472
C478	ELECTROLYTIC CAP. 1μF/50V M	CE1JMASDL1R0
C501	FILM CAP.(P) 0.22μF/100V J	CMA2AJS00224
C503	ELECTROLYTIC CAP. 100μF/35V M	CE1GMASDL101
C504	ELECTROLYTIC CAP. 2.2μF/50V LL	CE1JMASLH2R2
C505	ALUMINUM ELECTROLYTIC CAP 1000μF/25V M	CE1EMZNTM102
C506	ALUMINUM ELECTROLYTIC CAP 470μF/35V M	CE1GMZNTM471
C507	FILM CAP.(P) 0.033μF/50V J	CMA1JJS00333
C520▲	ELECTROLYTIC CAP. 1μF/50V M	CE1JMASDL1R0
C555	METALIZED PLYESTER CAP. 1μF/100V J	CT2A105MS065
C561	ELECTROLYTIC CAP. 470μF/6.3V M	CE0KMASDL471
C566▲	PP CAP. 0.0015μF/1.6KV J	CA3C152VC010
C567▲	PP CAP. 0.0033μF/1.6KV J	CA3C332VC010
C568	ALUMINUM ELECTROLYTIC CAP 100μF/160V M	CE2CMZPTM101
C571▲	PP CAP. 0.33μF/250V J	CT2E334MS041
C572▲	PP CAP. 0.27μF/250V J	CT2E274MS041
C574▲	ELECTROLYTIC CAP. 22μF/250V M	CE2EMASDL220
C577	ELECTROLYTIC CAP. 47μF/35V M	CE1GMASDL470
C578	FILM CAP.(P) 0.01μF/50V J	CMA1JJS00103
C580▲	PP CAP. 0.012μF/1.6KV J	CA3C123VC010
C582▲	P.P.CAP. 0.027μF/630V J	CBP2KKD00273
C584▲	METALIZED FILM CAP. 0.01μF/250V M	CT2E103MS037
C594▲	ELECTROLYTIC CAP. 10μF/50V M	CE1JMASDL100
C596	CERAMIC CAP. B K 100pF/500V	CCD2JKS0B101
C601▲	METALIZED FILM CAP. 0.33μF/250V	CT2E334MS037
C602▲	METALIZED FILM CAP. 0.22μF/250V	CT2E224MS037
C605	CERAMIC CAP. F Z 0.01μF/500V	CCD2JZP0F103
C606	CERAMIC CAP. F Z 0.01μF/500V	CCD2JZP0F103
C609	CERAMIC CAP. BN 820pF/2KV	CCD3DKA0B821
C610▲	ELECTROLYTIC CAP. 470μF/200V LX	CA2D471S6017
C611	FILM CAP.(P) 0.022μF/50V J	CMA1JJS00223
C614	FILM CAP.(P) 0.0018μF/50V J	CMA1JJS00182
C616	FILM CAP.(P) 0.082μF/50V J	CMA1JJS00823
C642▲	CERAMIC CAP. 0.0047μF F CS	COG2HMN0F472
C650	CERAMIC CAP. BN 680pF/2KV	CCD3DKA0B681
C652	CERAMIC CAP. B K 2200pF/500V	CCD2JKS0B222
C653	ELECTROLYTIC CAP. 2200μF/6.3V	CE0KMASDL222
C654	ELECTROLYTIC CAP. 1μF/50V M	CE1JMASDL1R0
C655	FILM CAP.(P) 0.047μF/50V J	CMA1JJS00473
C656	ALUMINUM ELECTROLYTIC CAP 100μF/160V M	CE2CMZPTM101
C657	ALUMINUM ELECTROLYTIC CAP 470μF/35V M	CE1GMZNTM471
C658	ALUMINUM ELECTROLYTIC CAP 1000μF/16V M	CE1CMZNTM102
C659	ELECTROLYTIC CAP. 2200μF/6.3V	CE0KMASDL222
C662	ALUMINUM ELECTROLYTIC CAP 1000μF/16V M	CE1CMZNTM102
C663	CHIP CERAMIC CAP.(1608) B K 4700pF/50V	CHD1JK30B472
C665	CERAMIC CAP. B K 680pF/50V	CCD1JKS0B681

Ref. No.	Description	Part No.
C666	CERAMIC CAP. B K 680pF/50V	CCD1JKS0B681
C667	ELECTROLYTIC CAP. 1μF/50V M	CE1JMASDL1R0
C674	ELECTROLYTIC CAP. 1μF/50V M	CE1JMASDL1R0
C681	ELECTROLYTIC CAP. 10μF/50V M	CE1JMASDL100
C682	ELECTROLYTIC CAP. 100μF/10V M	CE1AMASDL101
C684	ELECTROLYTIC CAP. 1000μF/10V M	CE1AMASDL102
C685	ELECTROLYTIC CAP. 100μF/10V M	CE1AMASDL101
C705	CHIP CERAMIC CAP.(1608) B K 3300pF/50V	CHD1JK30B332
C706	ELECTROLYTIC CAP. 1μF/50V M	CE1JMASDL1R0
C708	CHIP CERAMIC CAP.(1608) B K 3300pF/50V	CHD1JK30B332
C709	CHIP CERAMIC CAP. F Z 1μF/10V	CHD1AZ30F105
C725	CHIP CERAMIC CAP.(1608) B K 3300pF/50V	CHD1JK30B332
C726	CHIP CERAMIC CAP. F Z 1μF/10V	CHD1AZ30F105
C728	CHIP CERAMIC CAP.(1608) B K 3300pF/50V	CHD1JK30B332
C729	CHIP CERAMIC CAP. F Z 1μF/10V	CHD1AZ30F105
C731	CHIP CERAMIC CAP.(1608) B K 3300pF/50V	CHD1JK30B332
C733	ELECTROLYTIC CAP. 1μF/50V M	CE1JMASDL1R0
C736	CHIP CERAMIC CAP.(1608) B K 3300pF/50V	CHD1JK30B332
C738	ELECTROLYTIC CAP. 1μF/50V M	CE1JMASDL1R0
C752	CHIP CERAMIC CAP.(1608) B K 3300pF/50V	CHD1JK30B332
C762	CHIP CERAMIC CAP.(1608) B K 3300pF/50V	CHD1JK30B332
C773	ELECTROLYTIC CAP. 100μF/10V M	CE1AMASDL101
C801	ELECTROLYTIC CAP. 220μF/25V M	CE1EMASDL221
C802	ELECTROLYTIC CAP. 220μF/25V M	CE1EMASDL221
C807	ELECTROLYTIC CAP. 22μF/50V M	CE1JMASDL220
C808	ELECTROLYTIC CAP. 1μF/50V M	CE1JMASDL1R0
C809	ELECTROLYTIC CAP. 1μF/50V M	CE1JMASDL1R0
C811	ALUMINUM ELECTROLYTIC CAP 1000μF/16V M	CE1CMZNTM102
C812	ELECTROLYTIC CAP. 22μF/50V M	CE1JMASDL220
C833	ELECTROLYTIC CAP. 100μF/16V M	CE1CMASDL101
C851	ELECTROLYTIC CAP. 10μF/50V M	CE1JMASDL100
C852	ELECTROLYTIC CAP. 10μF/50V M	CE1JMASDL100
C853	CHIP CERAMIC CAP.(1608) B K 3300pF/50V	CHD1JK30B332
C854	CERAMIC CAP.(AX) B 0.0033μF/6.3V	CKK1JKT0B332
C904	ELECTROLYTIC CAP. 100μF/6.3V M	CE0KMASDL101
C905	ELECTROLYTIC CAP. 100μF/6.3V M	CE0KMASDL101
C906	ELECTROLYTIC CAP. 100μF/6.3V M	CE0KMASDL101
C907	ELECTROLYTIC CAP. 1000μF/6.3V M	CE0KMASDL102
C908	ELECTROLYTIC CAP. 100μF/6.3V M	CE0KMASDL101
C909	ELECTROLYTIC CAP. 0.47μF/50V M	CE1JMASDLR47
C910	ELECTROLYTIC CAP. 33μF/16V M	CE1CMASDL330
C931	ELECTROLYTIC CAP. 47μF/16V M	CE1CMASDL470
C932	CHIP CERAMIC CAP. F Z 0.01μF/50V	CHD1JZ30F103
CONNECTORS		
CN301	242 SERIES CONNECTOR 224202105W1	J322C05TG001
CN571▲	CONNECTOR 5P(PB FREE) 200322305W8	J303C05TG001
CN691▲	CONNECTOR 2P(PB FREE) 200322302W8	J303C02TG001
CN801	CONNECTOR PRINT OSU 008283021200000S+	J383C02UG004
CN802	CONNECTOR PRINT OSU 008283021200000S+	J383C02UG004
DIODES		
D11	PCB JUMPER D0.6-P5.0	JW5.0T
D301	ZENER DIODE MTZJT-775.1B	QDTB0MTZJ5R1
D302	ZENER DIODE MTZJT-775.1B	QDTB0MTZJ5R1
D303	ZENER DIODE MTZJT-775.1B	QDTB0MTZJ5R1
D381	ZENER DIODE MTZJT-779.1B	QDTB0MTZJ9R1
D382	SWITCHING DIODE 1SS133(T-77)	QDTZ001SS133
D383	ZENER DIODE MTZJT-7712B	QDTB00MTZJ12
D390	SWITCHING DIODE 1SS133(T-77)	QDTZ001SS133
D391	SWITCHING DIODE 1SS133(T-77)	QDTZ001SS133
D501	SCHOTTKY BARRIER DIODE SB140	NDQZ000SB140

Ref. No.	Description	Part No.
D502▲	ZENER DIODE MTZJT-7722B	QDTB00MTZJ22
D503▲	SWITCHING DIODE 1SS133(T-77)	QDTZ001SS133
D553	ZENER DIODE MTZJT-7715B	QDTB00MTZJ15
D557	SWITCHING DIODE 1SS133(T-77)	QDTZ001SS133
D558	SWITCHING DIODE 1SS133(T-77)	QDTZ001SS133
D572	DIODE FR104-B	NDLZ000FR104
D580▲	DIODE ERD07-15	QDLZ00ERD0715
D582▲	FAST RECOVERY DIODE ERD38-06	QDQZ00ERD3806
D583	SWITCHING DIODE 1SS133(T-77)	QDTZ001SS133
D585	SWITCHING DIODE 1SS133(T-77)	QDTZ001SS133
D586	DIODE FR104-B	NDLZ000FR104
D591▲	ZENER DIODE MTZJT-7736B	QDTB00MTZJ36
D594▲	SWITCHING DIODE 1SS133(T-77)	QDTZ001SS133
D595▲	SWITCHING DIODE 1SS133(T-77)	QDTZ001SS133
D597	ZENER DIODE MTZJT-774.3B	QDTB0MTZJ4R3
D605▲	DIODE 1N5406	NDLZ001N5406
D606▲	DIODE 1N5406	NDLZ001N5406
D607▲	DIODE 1N5406	NDLZ001N5406
D608▲	DIODE 1N5406	NDLZ001N5406
D611▲	ZENER DIODE MTZJT-7724C	QDTC00MTZJ24
D612▲	ZENER DIODE MTZJT-7739B	QDTB00MTZJ39
D613	ZENER DIODE MTZJT-774.3B	QDTB0MTZJ4R3
D614	SWITCHING DIODE 1SS133(T-77)	QDTZ001SS133
D615▲	SWITCHING DIODE 1N4148 T-77	QDTZ001N4148
D623	SWITCHING DIODE 1SS133(T-77)	QDTZ001SS133
D624	SWITCHING DIODE 1SS133(T-77)	QDTZ001SS133
D633	SWITCHING DIODE 1SS133(T-77)	QDTZ001SS133
D650	RECTIFIER DIODE FR202-B/P	NDQZ000FR202
D651	DIODE ERD29-06J	QD4Z00ERD2906
D652	DIODE FR154	NDLZ000FR154
D653	DIODE FR154	NDLZ000FR154
D654	DIODE FR104-B	NDLZ000FR104
D655	DIODE ZENER 1ZB180(Q)	QDLZ01ZB180Q
D656▲	ZENER DIODE MTZJT-777.5B	QDTB0MTZJ7R5
D657	DIODE FR154	NDLZ000FR154
D659	SCHOTTKY BARRIER DIODE SB340	NDWZ000SB340
D661▲	SWITCHING DIODE 1SS133(T-77)	QDTZ001SS133
D662	ZENER DIODE MTZJT-778.2B	QDTB0MTZJ8R2
D663	SWITCHING DIODE 1SS133(T-77)	QDTZ001SS133
D666	ZENER DIODE MTZJT-7733B	QDTB00MTZJ33
D670	SCHOTTKY BARRIER DIODE SB140	NDQZ000SB140
D671	SWITCHING DIODE 1SS133(T-77)	QDTZ001SS133
D672	SWITCHING DIODE 1SS133(T-77)	QDTZ001SS133
D676	ZENER DIODE MTZJT-7715B	QDTB00MTZJ15
D681	CARBON RES. 1/4W J 3.3 Ω	RCX4JATZ03R3
D696	SWITCHING DIODE 1SS133(T-77)	QDTZ001SS133
D841▲	SWITCHING DIODE 1SS133(T-77)	QDTZ001SS133
D842▲	ZENER DIODE MTZJT-775.1B	QDTB0MTZJ5R1
D904	SWITCHING DIODE 1SS133(T-77)	QDTZ001SS133
D905	SWITCHING DIODE 1SS133(T-77)	QDTZ001SS133
D906	SWITCHING DIODE 1SS133(T-77)	QDTZ001SS133
D907	SWITCHING DIODE 1SS133(T-77)	QDTZ001SS133
D908	SWITCHING DIODE 1SS133(T-77)	QDTZ001SS133
D909	ZENER DIODE MTZJT-776.2A	QDTA0MTZJ6R2
D910	SWITCHING DIODE 1SS133(T-77)	QDTZ001SS133
<b>ICS</b>		
IC31	IC VIF/SIF M61116FP TFOG	QSZBA0SHT034
IC301	MICRO-COMPUTER/VCD R2J10051-M02FP-RF0S	QSZAA0RHT112
IC381	IC SHUNT REGULATOR KIA431-AT/P	NSZBA0TJY036
IC421	IC BR24L64F-WE2	QSZBA0TRM071
IC451	IC MTS DECORDER AN5832SA-E1V	QSZBA0TMS003
IC551▲	IC VERTICAL OUTPUT LA78041-E	QSZBA0SSY006

Ref. No.	Description	Part No.
IC601▲	PHOTOCOUPLER LTV-817C-F	NPEC0LTV817F
IC701	IC SWITCHING TC4052BF(ELNF)	QSZBA0TTS162
IC801	IC AN17812A	QSZBA0SSMS017
IC903	VOLTAGE REGULATOR PQ070XF01SZH	QSZBA0SSH054
IC904	VOLTAGE REGULATOR PQ070XF01SZH	QSZBA0SSH054
IC905	IC SHUNT REGULATOR KIA431-AT	NSZLA0TJY036
IC911	IC SHUNT REGULATOR KIA431-AT/P	NSZBA0TJY036
<b>COILS</b>		
L12	INDUCTOR 33μH-H-K-5FT	LLARKBSTU330
L34	INDUCTOR 18μH-H-J-26T	LLAXJATTU180
L50	INDUCTOR 150μH-H-J-26T	LLAXJATTU151
L51	PCB JUMPER D0.6-P5.0	JW5.0T
L302	INDUCTOR 33μH-H-K-5FT	LLARKBSTU330
L303	INDUCTOR 33μH-H-K-5FT	LLARKBSTU330
L304	PCB JUMPER D0.6-P5.0	JW5.0T
L551	LINEARITY COIL ELH5L6136N	LLBD00PMS008
L562	CHOKO COIL ELC18B471LM	LLC471KMS001
L588	CHOKO COIL 47μH	LLBD00PKV022
L601▲	LINE FILTER JLB2460	LLBG00ZXB012
L901	CHOKO COIL 22μH-K	LLBD00PKV021
<b>TRANSISTORS</b>		
Q61	TRANSISTOR 2SC2785(F)	QQSF02SC2785
Q322	TRANSISTOR 2SA1175(F)	QQSF02SA1175
Q323▲	TRANSISTOR 2SC2785(F)	QQSF02SC2785
Q351	RES. BUILT-IN TRANSISTOR BA1F4M-T	QQSZ00BA1F4M
Q352	RES. BUILT-IN TRANSISTOR BA1F4M-T	QQSZ00BA1F4M
Q381	TRANSISTOR 2SC2785(F)	QQSF02SC2785
Q382	TRANSISTOR 2SC2785(F)	QQSF02SC2785
Q383	TRANSISTOR 2SC2120-O(TE2 F T)	QQS02SC2120F
Q552▲	TRANSISTOR 2SD1666R	QQER02SD1666
Q571▲	TRANSISTOR TT2142	QQZZ00TT2142
Q572	TRANSISTOR 2SC3708S	QQSS02SC3708
Q601▲	FET 2SK3869(Q)	QFWZ2SK3869Q
Q602▲	TRANSISTOR 2SC2120-O(TE2 F T)	QQS02SC2120F
Q631	TRANSISTOR 2SA1175(F)	QQSF02SA1175
Q647	TRANSISTOR 2SC2785(F)	QQSF02SC2785
Q652▲	TRANSISTOR 2SC2785(F)	QQSF02SC2785
Q672▲	TRANSISTOR 2SA1175(F)	QQSF02SA1175
Q673	TRANSISTOR 2SC2785(F)	QQSF02SC2785
Q674	TRANSISTOR 2SC2785(F)	QQSF02SC2785
Q681▲	TRANSISTOR 2SC2785(F)	QQSF02SC2785
Q682▲	TRANSISTOR 2SC2120-O(TE2 F T)	QQS02SC2120F
Q696	NPN TRANSISTOR KRC105M-AT/P	NQSZKRC105MP
Q811	TRANSISTOR 2SC2785(F)	QQSF02SC2785
Q901	TRANSISTOR 2SA950-O (TE2 F T)	QQS002SA950F
Q902	TRANSISTOR 2SC2785(F)	QQSF02SC2785
Q903	TRANSISTOR 2SC2120-O(TE2 F T)	QQS02SC2120F
Q904	TRANSISTOR 2SC2120-O(TE2 F T)	QQS02SC2120F
Q910	TRANSISTOR 2SC2120-O(TE2 F T)	QQS02SC2120F
Q911	RES. BUILT-IN TRANSISTOR BA1F4M-T	QQSZ00BA1F4M
<b>RESISTORS</b>		
R12	PCB JUMPER D0.6-P5.0	JW5.0T
R13	CHIP RES.(1608) 1/10W 0 Ω	RRXAJR5Z0000
R24	CARBON RES. 1/4W J 220 Ω	RCX4JATZ0221
R25	CHIP RES. 1/10W J 220 Ω	RRXAJR5Z0221
R31	CHIP RES. 1/10W J 22k Ω	RRXAJR5Z0223
R32	CARBON RES. 1/4W J 560 Ω	RCX4JATZ0561
R33	CHIP RES. 1/10W J 270 Ω	RRXAJR5Z0271
R35	CARBON RES. 1/4W J 1k Ω	RCX4JATZ0102
R37	CHIP RES. 1/10W J 220 Ω	RRXAJR5Z0221
R44	CHIP RES. 1/10W J 100 Ω	RRXAJR5Z0101
R50	CHIP RES. 1/10W J 2.2k Ω	RRXAJR5Z0222

Ref. No.	Description	Part No.
R51	CHIP RES. 1/10W J 330k Ω	RRXAJR5Z0334
R52	CHIP RES.(1608) 1/10W 0 Ω	RRXAJR5Z0000
R53	CHIP RES.(1608) 1/10W 0 Ω	RRXAJR5Z0000
R54	CHIP RES. 1/10W J 68k Ω	RRXAJR5Z0683
R61	CHIP RES. 1/10W J 1k Ω	RRXAJR5Z0102
R62	CHIP RES. 1/10W J 10k Ω	RRXAJR5Z0103
R63	CHIP RES. 1/10W J 10k Ω	RRXAJR5Z0103
R72	CHIP RES.(1608) 1/10W 0 Ω	RRXAJR5Z0000
R73	CHIP RES.(1608) 1/10W 0 Ω	RRXAJR5Z0000
R300	CHIP RES.(1608) 1/10W 0 Ω	RRXAJR5Z0000
R301	CHIP RES. 1/10W J 470 Ω	RRXAJR5Z0471
R302	CHIP RES. 1/10W J 560 Ω	RRXAJR5Z0561
R303	CHIP RES.(1608) 1/10W 0 Ω	RRXAJR5Z0000
R304	CHIP RES. 1/10W J 10k Ω	RRXAJR5Z0103
R305	CHIP RES.(1608) 1/10W 0 Ω	RRXAJR5Z0000
R306	CHIP RES.(1608) 1/10W 0 Ω	RRXAJR5Z0000
R309	CHIP RES. 1/10W J 100 Ω	RRXAJR5Z0101
R310	CHIP RES. 1/10W J 220 Ω	RRXAJR5Z0221
R311	CHIP RES. 1/10W J 6.8k Ω	RRXAJR5Z0682
R312	CHIP RES. 1/10W J 100 Ω	RRXAJR5Z0101
R314	CHIP RES. 1/10W J 10k Ω	RRXAJR5Z0103
R315	CHIP RES. 1/10W J 2.2k Ω	RRXAJR5Z0222
R317	CHIP RES. 1/10W J 100k Ω	RRXAJR5Z0104
R318	CHIP RES. 1/10W J 8.2k Ω	RRXAJR5Z0822
R320	CARBON RES. 1/4W J 33k Ω	RCX4JATZ0333
R322	CARBON RES. 1/4W J 47k Ω	RCX4JATZ0473
R323	CARBON RES. 1/4W J 2.2k Ω	RCX4JATZ0222
R324	CHIP RES.(1608) 1/10W 0 Ω	RRXAJR5Z0000
R325	CHIP RES. 1/10W J 150 Ω	RRXAJR5Z0151
R326	CHIP RES. 1/10W J 47k Ω	RRXAJR5Z0473
R327	CHIP RES. 1/10W J 10k Ω	RRXAJR5Z0103
R330	CHIP RES. 1/10W J 1k Ω	RRXAJR5Z0102
R331	CHIP RES.(1608) 1/10W 0 Ω	RRXAJR5Z0000
R332	CHIP RES. 1/10W J 330 Ω	RRXAJR5Z0331
R333	CHIP RES. 1/10W J 330 Ω	RRXAJR5Z0331
R335	CHIP RES. 1/10W J 22 Ω	RRXAJR5Z0220
R336	CHIP RES. 1/10W J 22 Ω	RRXAJR5Z0220
R337	CHIP RES. 1/10W J 22 Ω	RRXAJR5Z0220
R338	CHIP RES. 1/10W J 22 Ω	RRXAJR5Z0220
R339	CHIP RES. 1/10W J 22 Ω	RRXAJR5Z0220
R340	CHIP RES.(1608) 1/10W 0 Ω	RRXAJR5Z0000
R341	CHIP RES.(1608) 1/10W 0 Ω	RRXAJR5Z0000
R342	CHIP RES.(1608) 1/10W 0 Ω	RRXAJR5Z0000
R343	CHIP RES. 1/10W J 220 Ω	RRXAJR5Z0221
R351	CHIP RES. 1/10W J 100 Ω	RRXAJR5Z0101
R352	CHIP RES. 1/10W J 100 Ω	RRXAJR5Z0101
R353	CARBON RES. 1/4W J 100 Ω	RCX4JATZ0101
R354	CHIP RES.(1608) 1/10W 0 Ω	RRXAJR5Z0000
R355	CHIP RES.(1608) 1/10W 0 Ω	RRXAJR5Z0000
R356	CHIP RES.(1608) 1/10W 0 Ω	RRXAJR5Z0000
R357	PCB JUMPER D0.6-P5.0	JW5.0T
R358	CHIP RES.(1608) 1/10W 0 Ω	RRXAJR5Z0000
R359	CHIP RES.(1608) 1/10W 0 Ω	RRXAJR5Z0000
R360	CARBON RES. 1/4W J 22k Ω	RCX4JATZ0223
R361	CARBON RES. 1/4W J 10k Ω	RCX4JATZ0103
R362	CHIP RES. 1/10W J 10k Ω	RRXAJR5Z0103
R364	CHIP RES. 1/10W J 100 Ω	RRXAJR5Z0101
R365	CHIP RES. 1/10W J 100k Ω	RRXAJR5Z0104
R366	CHIP RES. 1/10W J 5.6k Ω	RRXAJR5Z0562
R367	CARBON RES. 1/4W J 220k Ω	RCX4JATZ0224
R368	CHIP RES. 1/10W J 10k Ω	RRXAJR5Z0103
R369	CHIP RES. 1/10W J 22k Ω	RRXAJR5Z0223
R370	CHIP RES. 1/10W J 2.2k Ω	RRXAJR5Z0222

Ref. No.	Description	Part No.
R373	CHIP RES. 1/10W J 22k Ω	RRXAJR5Z0223
R374	CHIP RES.(1608) 1/10W 0 Ω	RRXAJR5Z0000
R376	CHIP RES.(1608) 1/10W 0 Ω	RRXAJR5Z0000
R377	CHIP RES. 1/10W J 470 Ω	RRXAJR5Z0471
R378	CHIP RES. 1/10W J 2.2k Ω	RRXAJR5Z0222
R379	CHIP RES. 1/10W J 2.2k Ω	RRXAJR5Z0222
R380	CHIP RES. 1/10W J 2.2k Ω	RRXAJR5Z0222
R381	CARBON RES. 1/4W J 3.3 Ω	RCX4JATZ03R3
R382	CARBON RES. 1/4W J 10 Ω	RCX4JATZ0100
R383	CHIP RES.(1608) 1/10W F 3.6k Ω	RRXAFR5H0362
R384	CHIP RES. 1/10W F 10k Ω	RRXAFR5H1002
R385	CHIP RES. 1/10W J 2.2k Ω	RRXAJR5Z0222
R386	CHIP RES. 1/10W J 1.8k Ω	RRXAJR5Z0182
R387	CARBON RES. 1/4W J 5.6k Ω	RCX4JATZ0562
R388	CARBON RES. 1/4W J 5.6k Ω	RCX4JATZ0562
R389	CHIP RES. 1/10W J 2.2k Ω	RRXAJR5Z0222
R391	CHIP RES.(1608) 1/10W 0 Ω	RRXAJR5Z0000
R392	CHIP RES.(1608) 1/10W 0 Ω	RRXAJR5Z0000
R393	CHIP RES.(1608) 1/10W 0 Ω	RRXAJR5Z0000
R394	PCB JUMPER D0.6-P5.0	JW5.0T
R402	CHIP RES. 1/10W J 1.5k Ω	RRXAJR5Z0152
R403	CHIP RES. 1/10W J 2.2k Ω	RRXAJR5Z0222
R404	CHIP RES. 1/10W J 2.7k Ω	RRXAJR5Z0272
R405	CHIP RES. 1/10W J 4.7k Ω	RRXAJR5Z0472
R406	CHIP RES. 1/10W J 8.2k Ω	RRXAJR5Z0822
R407	CHIP RES. 1/10W J 10k Ω	RRXAJR5Z0103
R411	CARBON RES. 1/4W J 100 Ω	RCX4JATZ0101
R421	CHIP RES.(1608) 1/10W 0 Ω	RRXAJR5Z0000
R422	CHIP RES.(1608) 1/10W 0 Ω	RRXAJR5Z0000
R462	CHIP RES. 1/10W J 3.3k Ω	RRXAJR5Z0332
R466	CHIP RES.(1608) 1/10W 0 Ω	RRXAJR5Z0000
R467	CHIP RES.(1608) 1/10W 0 Ω	RRXAJR5Z0000
R468	CHIP RES. 1/10W J 180k Ω	RRXAJR5Z0184
R471	CARBON RES. 1/4W J 8.2k Ω	RCX4JATZ0822
R472	CHIP RES. 1/10W J 2.2k Ω	RRXAJR5Z0222
R476	CARBON RES. 1/4W J 8.2k Ω	RCX4JATZ0822
R477	CHIP RES. 1/10W J 2.2k Ω	RRXAJR5Z0222
R501	CHIP RES. 1/10W J 3.3k Ω	RRXAJR5Z0332
R503	CARBON RES. 1/4W J 22k Ω	RCX4JATZ0223
R504	CARBON RES. 1/4W J 1 Ω	RCX4JATZ01R0
R506	CARBON RES. 1/4W J 3.9 Ω	RCX4JATZ03R9
R507	CARBON RES. 1/4W J 3.9 Ω	RCX4JATZ03R9
R508	CARBON RES. 1/4W J 3.3 Ω	RCX4JATZ03R3
R513▲	METAL OXIDE FILM RES. 1W J 12 Ω	RN01120ZU001
R514	CARBON RES. 1/4W J 1k Ω	RCX4JATZ0102
R515	METAL OXIDE FILM RES. 1W J 12 Ω	RN01120ZU001
R520▲	CHIP RES. 1/10W J 10k Ω	RRXAJR5Z0103
R521	CARBON RES. 1/4W J 8.2k Ω	RCX4JATZ0822
R523	CHIP RES. 1/10W J 100k Ω	RRXAJR5Z0104
R530	CARBON RES. 1/4W J 680 Ω	RCX4JATZ0681
R531	CARBON RES. 1/4W J 680 Ω	RCX4JATZ0681
R532	CARBON RES. 1/4W J 680 Ω	RCX4JATZ0681
R537	CARBON RES. 1/4W J 1.5k Ω	RCX4JATZ0152
R551	METAL OXIDE FILM RES. 2W J 680 Ω	RN02681ZU001
R553	CARBON RES. 1/4W J 68k Ω	RCX4JATZ0683
R558	CHIP RES. 1/10W J 6.8k Ω	RRXAJR5Z0682
R560	METAL OXIDE FILM RES. 1W J 12 Ω	RN01120ZU001
R561	CARBON RES. 1/2W J 4.7 Ω	RCX2JZQZ04R7
R573	CHIP RES. 1/10W J 1k Ω	RRXAJR5Z0102
R574▲	CHIP RES. 1/10W J 1k Ω	RRXAJR5Z0102
R575▲	CARBON RES. 1/4W J 18 Ω	RCX4JATZ0180
R576▲	CARBON RES. 1/4W J 18 Ω	RCX4JATZ0180
R577	CARBON RES. 1/4W J 150 Ω	RCX4JATZ0151



Ref. No.	Description	Part No.
R578▲	CARBON RES. 1/4W J 18 Ω	RCX4JATZ0180
R579▲	CARBON RES. 1/4W J 22 Ω	RCX4JATZ0220
R581	PCB JUMPER D0.6-P5.0	JW5.0T
R582▲	CEMENT RESISTOR(PB FREE) 7W K 3.9 Ω	RW073R9KA049
R583▲	METAL OXIDE FILM RES.(STRAIGHT 1W J 1.5 Ω	RN01JZLZ01R5
R584▲	CARBON RES. 1/4W J 1k Ω	RCX4JATZ0102
R585	CARBON RES. 1/4W J 150 Ω	RCX4JATZ0151
R586	CARBON RES. 1/4W J 150 Ω	RCX4JATZ0151
R587	CARBON RES. 1/4W J 820k Ω	RCX4JATZ0824
R588	CARBON RES. 1/4W J 47k Ω	RCX4JATZ0473
R589	CARBON RES. 1/4W J 47k Ω	RCX4JATZ0473
R591▲	CARBON RES. 1/4W J 180k Ω	RCX4JATZ0184
R592▲	CARBON RES. 1/4W J 180k Ω	RCX4JATZ0184
R593▲	CARBON RES. 1/4W J 68k Ω	RCX4JATZ0683
R594▲	CARBON RES. 1/4W J 100k Ω	RCX4JATZ0104
R596	PCB JUMPER D0.6-P5.0	JW5.0T
R597	CARBON RES. 1/4W J 12k Ω	RCX4JATZ0123
R598▲	CARBON RES. 1/4W J 33k Ω	RCX4JATZ0333
R599▲	CARBON RES. 1/4W J 15k Ω	RCX4JATZ0153
R601▲	CEMENT RESISTOR 7W J 0.56 Ω H=25MM	RW07R56PAK11
R602▲	CARBON RES. 1/4W J 820k Ω	RCX4JATZ0824
R603	CARBON RES. 1/4W J 820k Ω	RCX4JATZ0824
R604	PCB JUMPER D0.6-P5.0	JW5.0T
R605	PCB JUMPER D0.6-P5.0	JW5.0T
R606	CARBON RES. 1/4W J 150k Ω	RCX4JATZ0154
R607	CARBON RES. 1/4W J 150 Ω	RCX4JATZ0151
R608	CARBON RES. 1/4W J 150 Ω	RCX4JATZ0151
R609	CARBON RES. 1/4W J 820k Ω	RCX4JATZ0824
R613▲	METAL OXIDE FILM RES. 2W J 0.22 Ω	RN02R22ZU001
R614	PCB JUMPER D0.6-P5.0	JW5.0T
R616	CARBON RES. 1/4W J 3.3k Ω	RCX4JATZ0332
R618	CARBON RES. 1/4W J 180 Ω	RCX4JATZ0181
R621	CARBON RES. 1/4W J 1.2k Ω	RCX4JATZ0122
R631	CARBON RES. 1/4W J 33k Ω	RCX4JATZ0333
R632	CARBON RES. 1/4W J 10k Ω	RCX4JATZ0103
R635	CARBON RES. 1/4W J 180 Ω	RCX4JATZ0181
R641	METAL OXIDE FILM RES. 1W J 5.6k Ω	RN01562ZU001
R643	CARBON RES. 1/4W J 27k Ω	RCX4JATZ0273
R644	CHIP RES. 1/10W J 27k Ω	RRXAJR5Z0273
R651	METAL OXIDE FILM RES. 1W J 5.6k Ω	RN01562ZU001
R653	METAL OXIDE FILM RES. 2W J 12k Ω	RN02123ZU001
R654	CARBON RES. 1/4W J 1.5k Ω	RCX4JATZ0152
R656	CHIP RES. 1/10W J 15k Ω	RRXAJR5Z0153
R657	CHIP RES. 1/10W J 15k Ω	RRXAJR5Z0153
R659	CHIP RES. 1/10W J 22k Ω	RRXAJR5Z0223
R661▲	CARBON RES. 1/4W J 33k Ω	RCX4JATZ0333
R662▲	CARBON RES. 1/4W J 27k Ω	RCX4JATZ0273
R663	CARBON RES. 1/4W J 8.2k Ω	RCX4JATZ0822
R664▲	CARBON RES. 1/4W J 560 Ω	RCX4JATZ0561
R665▲	CARBON RES. 1/4W J 6.8k Ω	RCX4JATZ0682
R666	CARBON RES. 1/4W J 1.5k Ω	RCX4JATZ0152
R667▲	CARBON RES. 1/4W J 6.8k Ω	RCX4JATZ0682
R668▲	CARBON RES. 1/4W J 6.8k Ω	RCX4JATZ0682
R669▲	CARBON RES. 1/4W J 6.8k Ω	RCX4JATZ0682
R670▲	CARBON RES. 1/4W J 33k Ω	RCX4JATZ0333
R671	CARBON RES. 1/4W J 22 Ω	RCX4JATZ0220
R673	CARBON RES. 1/4W J 100k Ω	RCX4JATZ0104
R674	CHIP RES. 1/10W J 22k Ω	RRXAJR5Z0223
R675▲	CARBON RES. 1/4W J 8.2k Ω	RCX4JATZ0822
R676	CHIP RES. 1/10W J 10k Ω	RRXAJR5Z0103
R677	CARBON RES. 1/4W J 27k Ω	RCX4JATZ0273
R678	CHIP RES. 1/10W J 56k Ω	RRXAJR5Z0563

Ref. No.	Description	Part No.
R680	CHIP RES. 1/10W J 10k Ω	RRXAJR5Z0103
R682▲	CARBON RES. 1/2W J 3.9 Ω	RCX2JZQZ03R9
R683▲	CARBON RES. 1/4W J 1.8 Ω	RCX4JATZ01R8
R684	CARBON RES. 1/4W J 1.8 Ω	RCX4JATZ01R8
R686	CARBON RES. 1/4W J 47 Ω	RCX4JATZ0470
R687	CARBON RES. 1/4W J 10 Ω	RCX4JATZ0100
R689	PCB JUMPER D0.6-P5.0	JW5.0T
R696	CARBON RES. 1/4W J 10 Ω	RCX4JATZ0100
R701	CARBON RES. 1/4W J 220 Ω	RCX4JATZ0221
R702	CARBON RES. 1/4W J 120 Ω	RCX4JATZ0121
R704	CHIP RES. 1/10W J 47k Ω	RRXAJR5Z0473
R705	CHIP RES. 1/10W J 18k Ω	RRXAJR5Z0183
R706	CHIP RES. 1/10W J 6.8k Ω	RRXAJR5Z0682
R707	CHIP RES. 1/10W J 47k Ω	RRXAJR5Z0473
R708	CHIP RES. 1/10W J 18k Ω	RRXAJR5Z0183
R709	CHIP RES. 1/10W J 6.8k Ω	RRXAJR5Z0682
R711	CHIP RES. 1/10W J 120 Ω	RRXAJR5Z0121
R716	CHIP RES. 1/10W J 75 Ω	RRXAJR5Z0750
R721	CHIP RES. 1/10W J 75 Ω	RRXAJR5Z0750
R724	CHIP RES. 1/10W J 47k Ω	RRXAJR5Z0473
R725	CHIP RES. 1/10W J 18k Ω	RRXAJR5Z0183
R726	CHIP RES. 1/10W J 6.8k Ω	RRXAJR5Z0682
R727	CHIP RES. 1/10W J 47k Ω	RRXAJR5Z0473
R728	CHIP RES. 1/10W J 18k Ω	RRXAJR5Z0183
R729	CHIP RES. 1/10W J 6.8k Ω	RRXAJR5Z0682
R731	CHIP RES. 1/10W J 47k Ω	RRXAJR5Z0473
R732	CHIP RES. 1/10W J 18k Ω	RRXAJR5Z0183
R733	CHIP RES. 1/10W J 6.8k Ω	RRXAJR5Z0682
R736	CHIP RES. 1/10W J 47k Ω	RRXAJR5Z0473
R737	CHIP RES. 1/10W J 18k Ω	RRXAJR5Z0183
R738	CHIP RES. 1/10W J 6.8k Ω	RRXAJR5Z0682
R746	CHIP RES. 1/10W J 75 Ω	RRXAJR5Z0750
R747	CHIP RES. 1/10W J 75 Ω	RRXAJR5Z0750
R748	CHIP RES. 1/10W J 75 Ω	RRXAJR5Z0750
R751	CHIP RES. 1/10W J 22k Ω	RRXAJR5Z0223
R752	CHIP RES. 1/10W J 27k Ω	RRXAJR5Z0273
R761	CARBON RES. 1/4W J 22k Ω	RCX4JATZ0223
R762	CHIP RES. 1/10W J 27k Ω	RRXAJR5Z0273
R771	CARBON RES. 1/4W J 10k Ω	RCX4JATZ0103
R772	CARBON RES. 1/4W J 10k Ω	RCX4JATZ0103
R805	CHIP RES. 1/10W J 330 Ω	RRXAJR5Z0331
R806	CHIP RES. 1/10W J 220k Ω	RRXAJR5Z0224
R811	CHIP RES. 1/10W J 10k Ω	RRXAJR5Z0103
R812	CHIP RES. 1/10W J 33k Ω	RRXAJR5Z0333
R813	CHIP RES. 1/10W J 820 Ω	RRXAJR5Z0821
R814	CHIP RES. 1/10W J 100 Ω	RRXAJR5Z0101
R841	METAL OXIDE FILM RES. 1W J 2.2 Ω	RN012R22ZU001
R842	CARBON RES. 1/4W J 560 Ω	RCX4JATZ0561
R843▲	CHIP RES. 1/10W J 2.2k Ω	RRXAJR5Z0222
R844▲	PCB JUMPER D0.6-P15.0	JW15.0T
R851	CHIP RES. 1/10W J 4.7k Ω	RRXAJR5Z0472
R852	CARBON RES. 1/4W J 2.2k Ω	RCX4JATZ0222
R853	CHIP RES. 1/10W J 4.7k Ω	RRXAJR5Z0472
R854	CHIP RES. 1/10W J 2.2k Ω	RRXAJR5Z0222
R863	CHIP RES. 1/10W J 10k Ω	RRXAJR5Z0103
R901	CARBON RES. 1/4W J 100k Ω	RCX4JATZ0104
R902	CHIP RES. 1/10W J 1k Ω	RRXAJR5Z0102
R903	CARBON RES. 1/4W J 3.3k Ω	RCX4JATZ0332
R904	CARBON RES. 1/4W J 1.2 Ω	RCX4JATZ01R2
R905	METAL RESISTOR 1W J 3.9 Ω	RN013R9ZU001
R906	CARBON RES. 1/4W J 220 Ω	RCX4JATZ0221
R907	PCB JUMPER D0.6-P5.0	JW5.0T
R908	CHIP RES.(1608) 1/10W F 2.2k Ω	RRXAFR5H0222

Ref. No.	Description	Part No.
R909	CHIP RES.(1608) 1/10W F 220k Ω	RRXAFR5H0224
R911	CARBON RES. 1/4W J 270 Ω	RCX4JATZ0271
R912	CHIP RES.(1608) 1/10W F 3.3k Ω	RRXAFR5H0332
R913	CHIP RES. 1/10W F 10k Ω	RRXAFR5H1002
R914	CARBON RES. 1/4W J 1.2k Ω	RCX4JATZ0122
R915	METAL OXIDE FILM RES. 1W J 5.6 Ω	RN015R6ZU001
R916	CHIP RES. 1/10W J 1.2k Ω	RRXAJR5Z0122
R917	CHIP RES.(1608) 1/10W 0 Ω	RRXAJR5Z0000
R918	CHIP RES.(1608) 1/10W 0 Ω	RRXAJR5Z0000
R919	CHIP RES. 1/10W J 5.6k Ω	RRXAJR5Z0562
R920	CHIP RES.(1608) 1/10W 0 Ω	RRXAJR5Z0000
R921	CHIP RES.(1608) 1/10W 0 Ω	RRXAJR5Z0000
R922	CARBON RES. 1/4W J 390 Ω	RCX4JATZ0391
R923	CHIP RES. 1/10W J 680 Ω	RRXAJR5Z0681
R924	CHIP RES.(1608) 1/10W 0 Ω	RRXAJR5Z0000
R925	CARBON RES. 1/4W J 220 Ω	RCX4JATZ0221
R926	CHIP RES. 1/10W J 820 Ω	RRXAJR5Z0821
R927	CHIP RES. 1/10W F 150 Ω	RRXAFR5H1500
R928	CHIP RES. 1/10W F 10k Ω	RRXAFR5H1002
R929	CHIP RES.(1608) 1/10W F 220 Ω	RRXAFR5H0221
R930	CHIP RES.(1608) 1/10W F 22k Ω	RRXAFR5H0223
R931	METAL OXIDE FILM RES. 2W J 0.22 Ω	RN02R22ZU001
R932	CARBON RES. 1/4W J 1.2 Ω	RCX4JATZ01R2
R933	CARBON RES. 1/2W J 2.7 Ω	RCX2JZQZ02R7
R934	CHIP RES.(1608) 1/10W F 4.7k Ω	RRXAFR5H0472
<b>SWITCHES</b>		
SW401	TACT SWITCH SKQSAB	SST0101AL038
SW402	TACT SWITCH SKQSAB	SST0101AL038
SW403	TACT SWITCH SKQSAB	SST0101AL038
SW404	TACT SWITCH SKQSAB	SST0101AL038
SW405	TACT SWITCH SKQSAB	SST0101AL038
SW406	TACT SWITCH SKQSAB	SST0101AL038
<b>MISCELLANEOUS</b>		
AC601▲	AC CORD LP-11W&PT218P-K90A&S	WAC0172LW020
B2	HEAT SINK(PKZ) ASSEMBLY L4800UZ	1EM422098
B3	HEAT SINK(PKS)ASSEMBLY L3820UA	1EM421044
B4	HEAT SINK(PKX)ASSEMBLY L4800UZ	1EM422090
B5	HEAT SINK(PLA) L4800UZ	1EM422099
B7	SHIELD PLATE L4800UZ	1EM422101
BC14	PCB JUMPER D0.6-P5.0	JW5.0T
BC15	BEAD INDUCTORS FBR07HA121TB-00	LLBF00ZTU021
BC571	BEAD INDUCTORS FBA04HA600VB-00	LLBF00STU026
BC572	BEAD INDUCTORS FBA04HA600VB-00	LLBF00STU026
BC603	BEAD INDUCTORS FBR07HA121TB-00	LLBF00ZTU021
BC652	BEAD INDUCTORS FBR07HA121TB-00	LLBF00ZTU021
BC653	BEAD INDUCTORS FBR07HA121TB-00	LLBF00ZTU021
BC655	BEAD INDUCTORS FBR07HA121TB-00	LLBF00ZTU021
BC657	BEAD INDUCTORS FBR07HA121TB-00	LLBF00ZTU021
BC691	BEAD INDUCTORS FBR07HA121TB-00	LLBF00ZTU021
CF32	CERAMIC FILTER SFSRA4M50CF00-B0	FBB455PMR004
CLN301	WIRE ASSEMBLY WX1L1200-102	WX1L1200-102
CLN501	WIRE ASSEMBLY WX1L1520-101	WX1L1520-101
F601▲	FUSE 4.00A/125V	PAGG20CNG402
FH601	FUSE HOLDER MSF-015 LF (B110)	XH01Z00LY002
FH602	FUSE HOLDER MSF-015 LF (B110)	XH01Z00LY002
GP641▲	GAP.FNR-G3.10D	FAZ000LD6005
JC13	CHIP RES.(1608) 1/10W 0 Ω	RRXAJR5Z0000
JC14	CHIP RES.(1608) 1/10W 0 Ω	RRXAJR5Z0000
JC15	CHIP RES.(1608) 1/10W 0 Ω	RRXAJR5Z0000
JC18	CHIP RES.(1608) 1/10W 0 Ω	RRXAJR5Z0000
JC702	CHIP RES.(1608) 1/10W 0 Ω	RRXAJR5Z0000
JC703	CHIP RES.(1608) 1/10W 0 Ω	RRXAJR5Z0000

Ref. No.	Description	Part No.
JC810	CHIP RES.(1608) 1/10W 0 Ω	RRXAJR5Z0000
JK701	JACK RCA PCB L AV1-09-023	JXRL010RP047
JK702	JACK RCA PCB L AV1-09-024	JXRL010RP048
JK703	JACK SW RCA PCB L AV1-09-032	JYRL010RP023
JK711	JACK SW RCA PCB L AV3-19-021	JYRL030RP026
JK721	Y/C JACK 1P(SW) DMDC1-01-021	JYEL040RP001
JK741	JACK RCA PCB L AV3-19-22	JXRL030RP044
JK742	RCA JACK(SW) MSP-213V2-132 NI FE	JYRL030LY028
JS571	PCB JUMPER D0.6-P5.0	JW5.0T
JS573	PCB JUMPER D0.6-P5.0	JW5.0T
JS801	PCB JUMPER D0.6-P5.0	JW5.0T
JS802	PCB JUMPER D0.6-P5.0	JW5.0T
L1	SCREW B-TIGHT D3X8 BIND HEAD+	GBMB3080
LD001	LEAD WIRE TC UL1015 AWG20 01/110/ AWG20/BLUE	WX3601CA5511
PS691▲	THERMISTOR ZPB45BL3R0A	QNBZ45BL3R0A
RCV401	REMOCON RECEIVE UNIT KSM-602SR2E-2	USESJR5K045
RL601▲	POWER RELAY SDT-S-112LMR	MRNDC12QN014
SA601▲	SURGE ABSORBER 470V+-10PER	NVQZ10D471KB
SF11	FILTER CERAMIC BAND PASS SAFHS45M7VAJZ00B05	FBB456LMR004
T571▲	FLYBACK TRANSFORMER JF0501-3301	LTF00CPXB046
T572	HORIZONTAL DRIVE TRANS(PB FREE PY2005	LTH00CPY2005
T601▲	SWITCHING TRANSFORMER 5752	LTT00CPKT199
TP601	PCB JUMPER D0.6-P18.5	JW18.5T
TU11	TUNER UNIT TDQU2	UTUNNTUAL048
VR661▲	CARBON P.O.T. VZ067TL1 B203 PB(F)	VRCB203HI014
X301	XTAL 3.579545 MHz	FXD355LLN003

## CRT CBA

Ref. No.	Description	Part No.
	CRT CBA Consists of the following:	-----
<b>CAPACITORS</b>		
C1502	ELECTROLYTIC CAP. 10μF/ 50V M	CE1JMASDL100
C1510	CERAMIC CAP. B K 2200pF/2KV	CCD3DKD0B222
C1511	CERAMIC CAP.(AX) B K 270pF/50V	CCA1JKT0B271
C1521	CERAMIC CAP.(AX) B K 270pF/50V	CCA1JKT0B271
C1531	CERAMIC CAP.(AX) B K 270pF/50V	CCA1JKT0B271
<b>CONNECTOR</b>		
CN1501	CONNECTOR PIN 1P RT-01N-2.3A	1730688
<b>DIODES</b>		
D1511	SWITCHING DIODE 1SS133(T-77)	QDTZ001SS133
D1521	SWITCHING DIODE 1SS133(T-77)	QDTZ001SS133
D1531	SWITCHING DIODE 1SS133(T-77)	QDTZ001SS133
<b>COIL</b>		
L1501	PCB JUMPER D0.6-P5.0	JW5.0T
<b>TRANSISTORS</b>		
Q1511	TRANSISTOR(PB FREE) KTC3503-Y/P	NQEYKTC3503P
Q1521	TRANSISTOR(PB FREE) KTC3503-Y/P	NQEYKTC3503P
Q1531	TRANSISTOR(PB FREE) KTC3503-Y/P	NQEYKTC3503P
<b>RESISTORS</b>		
R1501	CARBON RES. 1/4W J 100 Ω	RCX4JATZ0101
R1502	CARBON RES. 1/4W J 100 Ω	RCX4JATZ0101
R1503	CARBON RES. 1/4W J 100 Ω	RCX4JATZ0101
R1510▲	METAL RESISTOR 3W J 10k Ω	RN03103ZU001
R1511	CARBON RES. 1/4W J 1.5k Ω	RCX4JATZ0152
R1512	CARBON RES. 1/4W J 1.5k Ω	RCX4JATZ0152
R1515	CARBON RES. 1/4W J 1.2k Ω	RCX4JATZ0122
R1518	CARBON RES. 1/4W J 330 Ω	RCX4JATZ0331
R1519	CHIP RES. 1/10W J 100 Ω	RRXAJR5Z0101
R1520▲	METAL RESISTOR 3W J 10k Ω	RN03103ZU001

Ref. No.	Description	Part No.
R1521	CARBON RES. 1/4W J 1.5k $\Omega$	RCX4JATZ0152
R1522	CARBON RES. 1/4W J 1.5k $\Omega$	RCX4JATZ0152
R1525	CARBON RES. 1/4W J 1.2k $\Omega$	RCX4JATZ0122
R1528	CARBON RES. 1/4W J 330 $\Omega$	RCX4JATZ0331
R1529	CHIP RES. 1/10W J 100 $\Omega$	RRXAJR5Z0101
R1530▲	METAL RESISTOR 3W J 10k $\Omega$	RN03103ZU001
R1531	CARBON RES. 1/4W J 1.5k $\Omega$	RCX4JATZ0152
R1532	CARBON RES. 1/4W J 1.5k $\Omega$	RCX4JATZ0152
R1535	CARBON RES. 1/4W J 1.2k $\Omega$	RCX4JATZ0122
R1538	CARBON RES. 1/4W J 330 $\Omega$	RCX4JATZ0331
R1539	CHIP RES. 1/10W J 100 $\Omega$	RRXAJR5Z0101
<b>MISCELLANEOUS</b>		
BC1501	BEAD INDUCTORS FBR07HA121TB-00	LLBF00ZTU021
JK1501▲	CRT SOCKET ISHD40S	JSCC290PK008
JS1511	PCB JUMPER D0.6-P5.0	JW5.0T
JS1521	PCB JUMPER D0.6-P5.0	JW5.0T
JS1531	PCB JUMPER D0.6-P5.0	JW5.0T

